

The right offer
for every requirement:
the new IndustryLine.





Since its foundation in 1934, Stabilus has developed into the leading company in the sector, with innovative products and uncompromising quality. HAHN Gasfedern, another pioneer in gas spring technology, has been part of the Stabilus Group since 2016. We are now taking the next step together.

Our new IndustryLine immediately expands our product and service offer. Customers who need individual solutions, fast and agile development processes, and who seek small series or single units will find the perfect gas springs in the IndustryLine offer. And of course all at the usual high quality. All products are developed, produced and supplied in accordance with the highest standards of quality. Specially-trained employees monitor compliance with our quality criteria at every stage of the production process. We are certified under DIN ISO 9001, DIN EN ISO 50001 and DIN ISO 14001, and we produce both Reach-conform and in accordance with RoHS guidelines. We place great value on strict quality standards when choosing our sales and service partners.

Hardly any manufacturer in gas spring technology offers such a wide product range as the Stabilus Group. The product range includes gas springs, locking and tension springs, release systems, dampers, special types, brackets and fittings in various different sizes and materials.

Stabilus IndustryLine supplies you with a wide range of products in next to no time. State-of-the-art production sites allow us to manufacture individual or special designs with short lead times.

In the field of gas springs and oil dampers, the name Stabilus IndustryLine stands for highest-level competence in development, quality and consulting as well as short delivery times and adherence to delivery dates.





Contents

- 6 Design and function
- 7 Order system
- 8 – 11 Gas springs
- 14 – 17 Tension springs
- 18 – 19 Oil dampers
- 20 – 21 Double-stroke springs
- 22 – 25 Fittings
- 26 – 29 Brackets
- 30 – 31 Extras and technical instructions

Stabilus IndustryLine gas springs are used for all applications that require the controlled moving and braking of weights without having to apply strong forces.

Gas springs by Stabilus IndustryLine are used in virtually every field today. In commercial vehicles, construction machinery, agricultural and buses as well as in the furniture industry, engineering, for sports, leisure and home appliances, in medical engineering and other areas of industrial and private use. For special applications in medical engineering, the chemicals and food industry and ship-building, we manufacture our products in stainless steel. We produce all types and series in AISI 303/304 and AISI 316L/316Ti. Our gas springs in AISI 316L/316Ti are resistant to chemicals. This catalog will provide you with an overview of our broad product range.

One of the special strengths of Stabilus is the development of customer-specific solutions. A highly-qualified team, state-of-the-art CAD workplaces and high-quality machinery allow us to find solutions for your application challenges and to realize them with short lead times.

The staff of the company Stabilus and your local sales partner will be happy to support you in finding your product.

STABILUS INDUSTRYLINE

Order system

Step 1:

Selection of the product

G = Gas spring

Z = Tension spring

ZD = Tension spring with damping

upon request

F = Elastic locking gas spring

S = Rigid locking gas spring

X = Absolutely rigid locking gas spring

SL = Free-moving locking gas spring

SX = Double rigid locking gas spring

D = Non-adjustable oil damper

Step 2:

Select a series on the basis of the required force, the desired stroke and the maximum installation length.

Step 3:

Enter the desired stroke in mm.

G 1 4 2 8 0 2 5 0 1 0 6 5 0 A U 2 7 A B 1 6 1 5 0 0 N 1 5 6 V2

Step 4:

Select the damping (1=with, 0=without damping, 9=special nozzle) or the braking direction (1=extension, 2=compression, 3=in both directions).

Step 5:

Enter the installation length in mm (extended from middle to middle of fitting).

Step 6:

Determine the fitting at the piston rod.

Step 7:

Determine the fitting at the cylinder.

Step 8:

Enter the desired nominal force in N.

Step 9:

Selection of the extras

1 = Wiper ring

2 = Radial valve

4 = Grease chamber

5 = Valve

6 = Protection tube

7 = Floating piston (add 70% of the stroke length to the determined installation length)

8 = Locking device (add 30 mm to the determined installation length)

B3 = Sealing system

NT = Low-temperature design

HT = High-temperature design

RK = Friction element

V2 = Design completely in stainless steel AISI 303/304

V4 = Design completely in stainless steel AISI 316L/316Ti





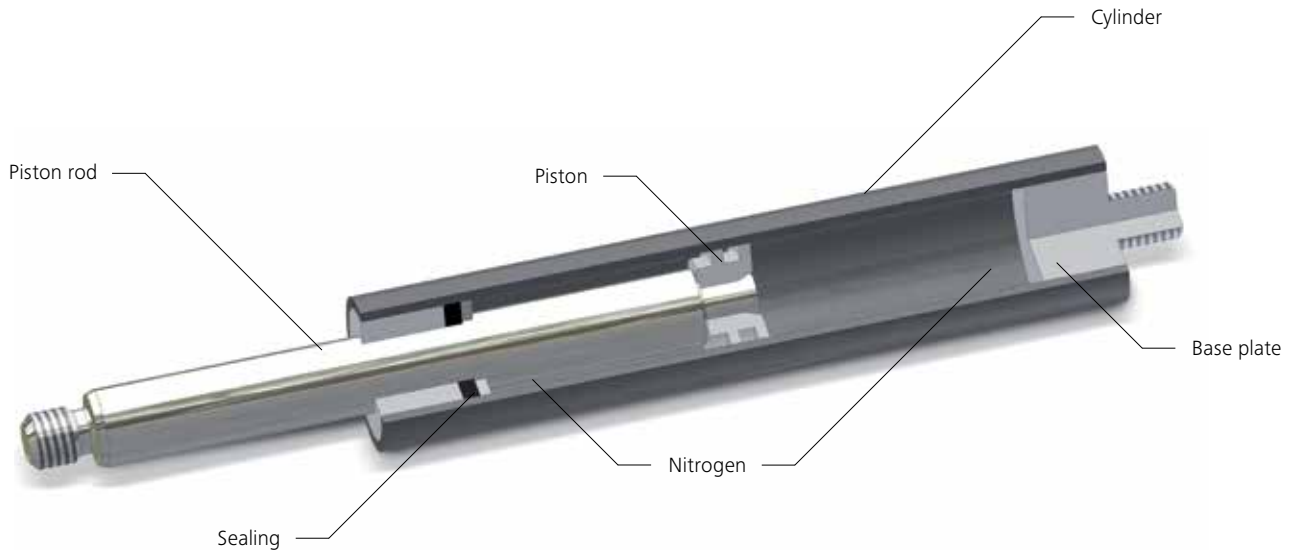

Stabilus gas springs are hydro pneumatic, closed and maintenance-free adjustable elements. The spring force F_1 results from the internal pressure in the cylinder, which is generated by the filling medium nitrogen. On the gas spring, this pressure is applied to the cross-section of the piston rod. When no load is applied, the piston rod is always extended.

By pushing in the piston rod, the volume in the cylinder is reduced, and the gas is compressed. Thus the gas spring force increases (progression) depending on the diameter of the piston rod and the volume of the cylinder. Stabilus IndustryLine gas springs contain an oil filling for lubrication and end damping.

Stabilus IndustryLine gas springs are available in steel, AISI 303/304 and AISI 316L/316Ti.

State-of-the-art production sites with CNC-controlled machines are the basis for ultimate safety, quality and durability.



Product range of the STABILUS IndustryLine gas springs

The stock program of the STABILUS IndustryLine allows you to quickly access many gas pressure and gas tension springs in steel and stainless steel, as well as the appropriate connections and fittings.

Our sales team will be pleased to assist you in selecting the right spring for you. You can also configure your own spring. Please follow these instructions:

1. Select the appropriate product, series, material and stroke from the lists. Determine the required force and respect the force range permitted for the spring.

Example

Type	Stroke (H)	Length (L)	Thread	Force
G1023	150 mm	345 mm	M8	100–1200 N

2. Select the desired connections, matching the thread of the gas spring, out of the stock program. In addition a variety of fittings (page 22–25), which can also be used to adjust the total length (TL). Add the installation length of the connections (A) to the length (L) of the gas spring.

Example

Type	Thread	Installation length (A)	Thickness (B)	Width (C)	Cross hole Ø (D)	Steel	AISI 303
AU19	M8	19 mm	10 mm	14 mm	8.1 mm	1	1
PF30	M8	30 mm	13 mm	–	–	1	1

L (length gas spring) + A1(connection Rod) + A2(connection cylinder) = TL (total length). Example: 345 mm (G10-23-150 stroke) + 19 mm (AU19) + 30 mm (PF30) = 394 mm



Example of item 1 and 2

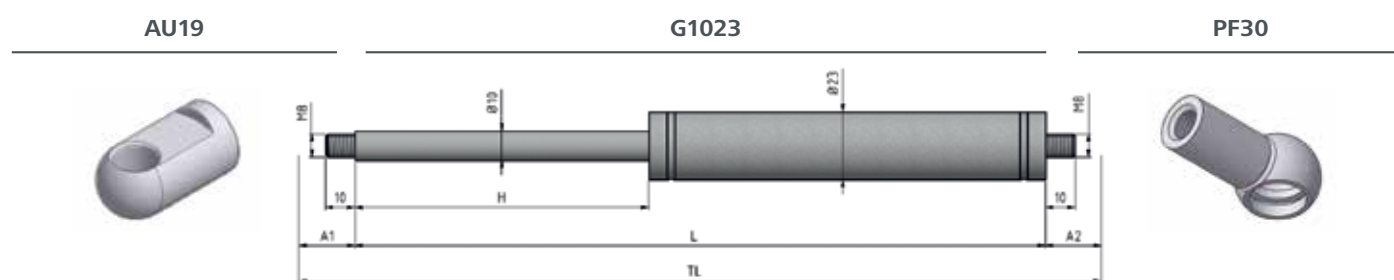

3. Congratulations: You have configured your desired gas spring. Please do not forget to order the appropriate brackets (page 27–29). Example: BC01 (for eyelet), BA20/K13 (for socket)



4. Please ask your STABILUS IndustryLine dealer for price and delivery time.

STABILUS IndustryLine stands for high quality, innovative products, as well as flexibility and speed in the implementation of your wishes.

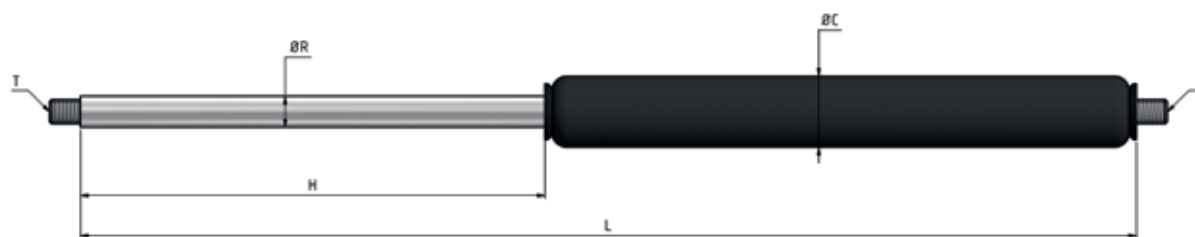

Gas spring – Steel (piston rod: chromium-plated, cylinder: black spray coated)

Type	Ø Rod (R)	Ø Cylinder (C)	Stroke (H)	Length (L)	Thread (T) on both sides	Force
G 04 12	4 mm	12 mm	30 mm	92 mm	M3,5 x 5 mm	10–180N
G 04 12	4 mm	12 mm	50 mm	132 mm	M3,5 x 5 mm	10–180N
G 04 12	4 mm	12 mm	60 mm	152 mm	M3,5 x 5 mm	10–180N
G 04 12	4 mm	12 mm	80 mm	192 mm	M3,5 x 5 mm	10–180N
G 04 12	4 mm	12 mm	100 mm	232 mm	M3,5 x 5 mm	10–180N
G 04 12	4 mm	12 mm	120 mm	272 mm	M3,5 x 5 mm	10–180N
G 04 12	4 mm	12 mm	150 mm	332 mm	M3,5 x 5 mm	10–180N

Type	Ø Rod (R)	Ø Cylinder (C)	Stroke (H)	Length (L)	Thread (T) on both sides	Force
G 06 15	6 mm	15 mm	50 mm	132 mm	M5 x 5 mm	40–400N
G 06 15	6 mm	15 mm	60 mm	152 mm	M5 x 5 mm	40–400N
G 06 15	6 mm	15 mm	80 mm	192 mm	M5 x 5 mm	40–400N
G 06 15	6 mm	15 mm	100 mm	232 mm	M5 x 5 mm	40–400N
G 06 15	6 mm	15 mm	120 mm	272 mm	M5 x 5 mm	40–400N
G 06 15	6 mm	15 mm	150 mm	332 mm	M5 x 5 mm	40–400N
G 06 15	6 mm	15 mm	200 mm	432 mm	M5 x 5 mm	40–400N

Type	Ø Rod (R)	Ø Cylinder (C)	Stroke (H)	Length (L)	Thread (T) on both sides	Force
G 08 19	8 mm	19 mm	50 mm	145 mm	M8 x 10 mm	50–700N
G 08 19	8 mm	19 mm	60 mm	165 mm	M8 x 10 mm	50–700N
G 08 19	8 mm	19 mm	80 mm	205 mm	M8 x 10 mm	50–700N
G 08 19	8 mm	19 mm	100 mm	245 mm	M8 x 10 mm	50–700N
G 08 19	8 mm	19 mm	120 mm	285 mm	M8 x 10 mm	50–700N
G 08 19	8 mm	19 mm	150 mm	345 mm	M8 x 10 mm	50–700N
G 08 19	8 mm	19 mm	160 mm	365 mm	M8 x 10 mm	50–700N
G 08 19	8 mm	19 mm	200 mm	445 mm	M8 x 10 mm	50–700N
G 08 19	8 mm	19 mm	250 mm	545 mm	M8 x 10 mm	50–700N
G 08 19	8 mm	19 mm	300 mm	645 mm	M8 x 10 mm	50–700N

Type	Ø Rod (R)	Ø Cylinder (C)	Stroke (H)	Length (L)	Thread (T) on both sides	Force
G 10 23	10 mm	23 mm	100 mm	245 mm	M8 x 10 mm	100–1200N
G 10 23	10 mm	23 mm	150 mm	345 mm	M8 x 10 mm	100–1200N
G 10 23	10 mm	23 mm	200 mm	445 mm	M8 x 10 mm	100–1200N
G 10 23	10 mm	23 mm	250 mm	545 mm	M8 x 10 mm	100–1200N
G 10 23	10 mm	23 mm	300 mm	645 mm	M8 x 10 mm	100–1200N
G 10 23	10 mm	23 mm	350 mm	745 mm	M8 x 10 mm	100–1200N
G 10 23	10 mm	23 mm	400 mm	845 mm	M8 x 10 mm	100–1200N

Type	Ø Rod (R)	Ø Cylinder (C)	Stroke (H)	Length (L)	Thread (T) on both sides	Force
G 14 28	14 mm	28 mm	100 mm	248 mm	M10 x 12 mm	150–2500N
G 14 28	14 mm	28 mm	150 mm	348 mm	M10 x 12 mm	150–2500N
G 14 28	14 mm	28 mm	200 mm	448 mm	M10 x 12 mm	150–2500N
G 14 28	14 mm	28 mm	250 mm	546 mm	M10 x 12 mm	150–2500N
G 14 28	14 mm	28 mm	300 mm	648 mm	M10 x 12 mm	150–2500N
G 14 28	14 mm	28 mm	350 mm	748 mm	M10 x 12 mm	150–2500N
G 14 28	14 mm	28 mm	400 mm	848 mm	M10 x 12 mm	150–2500N
G 14 28	14 mm	28 mm	450 mm	948 mm	M10 x 12 mm	150–2500N
G 14 28	14 mm	28 mm	500 mm	1048 mm	M10 x 12 mm	150–2500N

Gas spring – Stainless Steel 303 (piston rod: AISI 303, cylinder: AISI 304)

Type	Ø Rod (R)	Ø Cylinder (C)	Stroke (H)	Length (L)	Thread (T) on both sides	Force
G 06 15	6 mm	15 mm	80 mm	192 mm	M5 x 7 mm	40–400N
G 06 15	6 mm	15 mm	100 mm	232 mm	M5 x 7 mm	40–400N
G 06 15	6 mm	15 mm	150 mm	332 mm	M5 x 7 mm	40–400N

Type	Ø Rod (R)	Ø Cylinder (C)	Stroke (H)	Length (L)	Thread (T) on both sides	Force
G 08 19	8 mm	19 mm	80 mm	205 mm	M8 x 10 mm	50–700N
G 08 19	8 mm	19 mm	100 mm	245 mm	M8 x 10 mm	50–700N
G 08 19	8 mm	19 mm	120 mm	285 mm	M8 x 10 mm	50–700N
G 08 19	8 mm	19 mm	150 mm	345 mm	M8 x 10 mm	50–700N
G 08 19	8 mm	19 mm	200 mm	445 mm	M8 x 10 mm	50–700N
G 08 19	8 mm	19 mm	250 mm	545 mm	M8 x 10 mm	50–700N

Type	Ø Rod (R)	Ø Cylinder (C)	Stroke (H)	Length (L)	Thread (T) on both sides	Force
G 10 23	10 mm	23 mm	100 mm	245 mm	M8 x 10 mm	100–1200N
G 10 23	10 mm	23 mm	150 mm	345 mm	M8 x 10 mm	100–1200N
G 10 23	10 mm	23 mm	200 mm	445 mm	M8 x 10 mm	100–1200N
G 10 23	10 mm	23 mm	250 mm	545 mm	M8 x 10 mm	100–1200N
G 10 23	10 mm	23 mm	300 mm	645 mm	M8 x 10 mm	100–1200N
G 10 23	10 mm	23 mm	350 mm	745 mm	M8 x 10 mm	100–1200N
G 10 23	10 mm	23 mm	400 mm	845 mm	M8 x 10 mm	100–1200N

You could not realize your desired gas spring with our stock program?

No problem. Our warehouse program is only a small part of our product portfolio. Send us your ideas, data about the product, or your application. We support you in the design of the appropriate gas spring, and manufacture the right product for you quickly and cost-effectively.

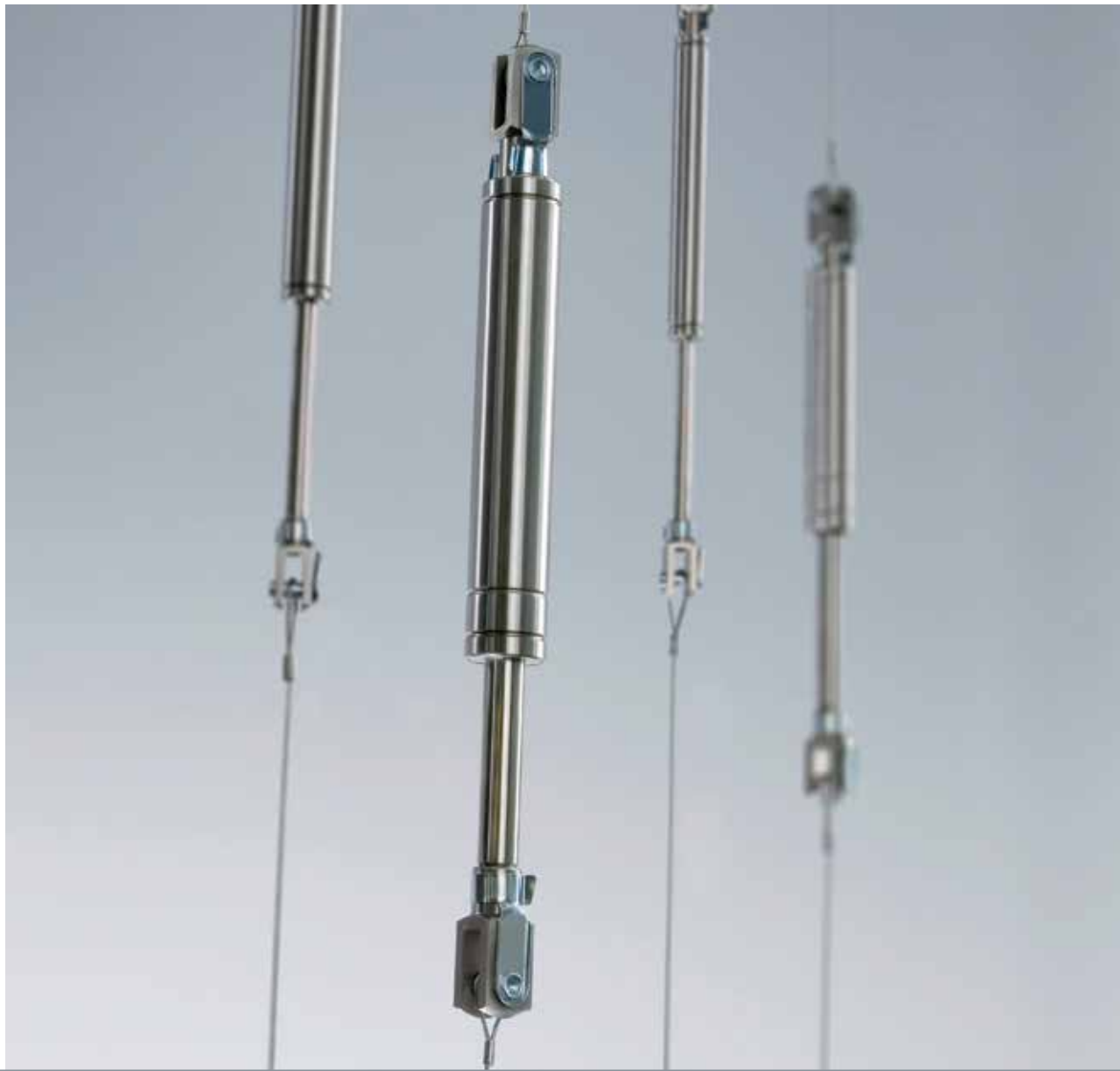

Stabilus IndustryLine tension springs are used for all applications where normal gas springs cannot be used for lack of space.

Tension springs work in the opposite way to gas springs. The gas pressure in the cylinder pulls the piston rod towards the inside. The spring force F_1 results from the internal pressure in the cylinder, which is generated by the filling medium nitrogen. In the tension spring, the piston ring area between the piston rod and the inside cylinder diameter is decisive. When no load is applied, the piston rod is always compressed. The tension springs of series 'Z' have no damping. Series ZD is available with damping.

Stabilus IndustryLine tension springs are available in steel, AISI 303/304 and AISI 316L /316Ti.

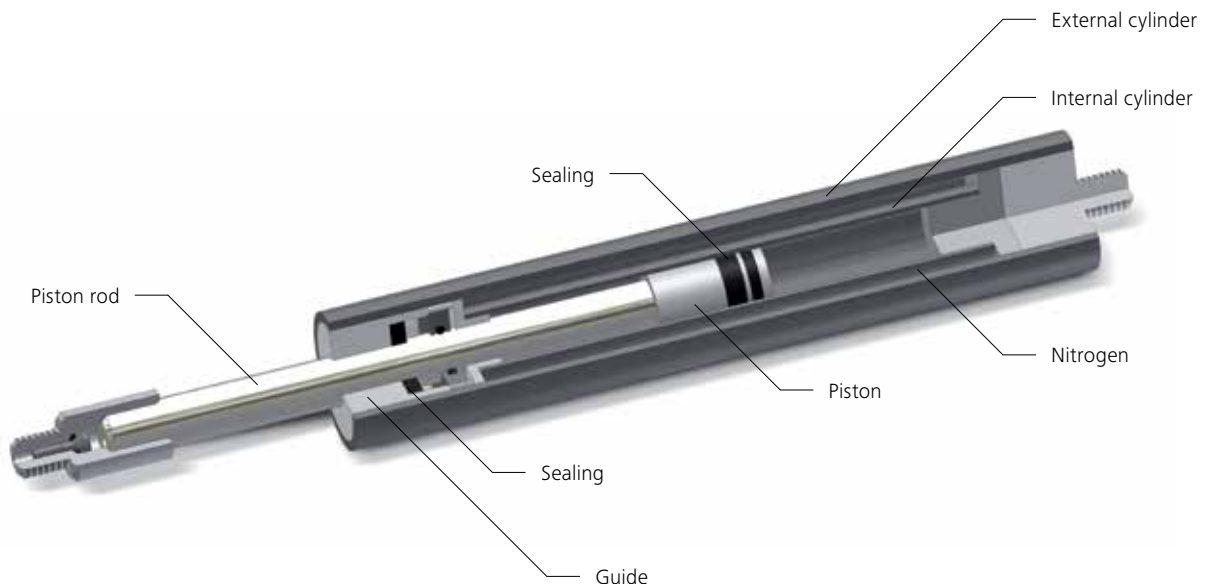

Experienced engineers and technicians support you in implementing your projects, and develop optimum solutions.



Product range of the STABILUS IndustryLine tension springs

Type	Ø Rod	Ø Cylinder	Stroke	Standard length	Tension force	Progression
Z 04-15	4 mm	15 mm	20–200 mm	2 x stroke + 63	50–300 N	22 %
Z 06-19	6 mm	19 mm	30–400 mm	2 x stroke + 100	30–350 N	29 %
Z 10-28	10 mm	28 mm	60–600 mm	2 x stroke + 100	150–1200 N	20 %
Z 10-40	10 mm	40 mm	10–590 mm	2 x stroke + 150	200–2000 N	78 %
Z 28-40	28 mm	40 mm	50–700 mm	2.5 x stroke + 125	500–5000 N	40 %

Tension spring with damping

Type	Ø Rod	Ø Cylinder	Stroke	Standard length	Tension force	Progression
ZD 10-28	10 mm	28 mm	20–600 mm	3 x stroke + 90	100–1200 N	36 %

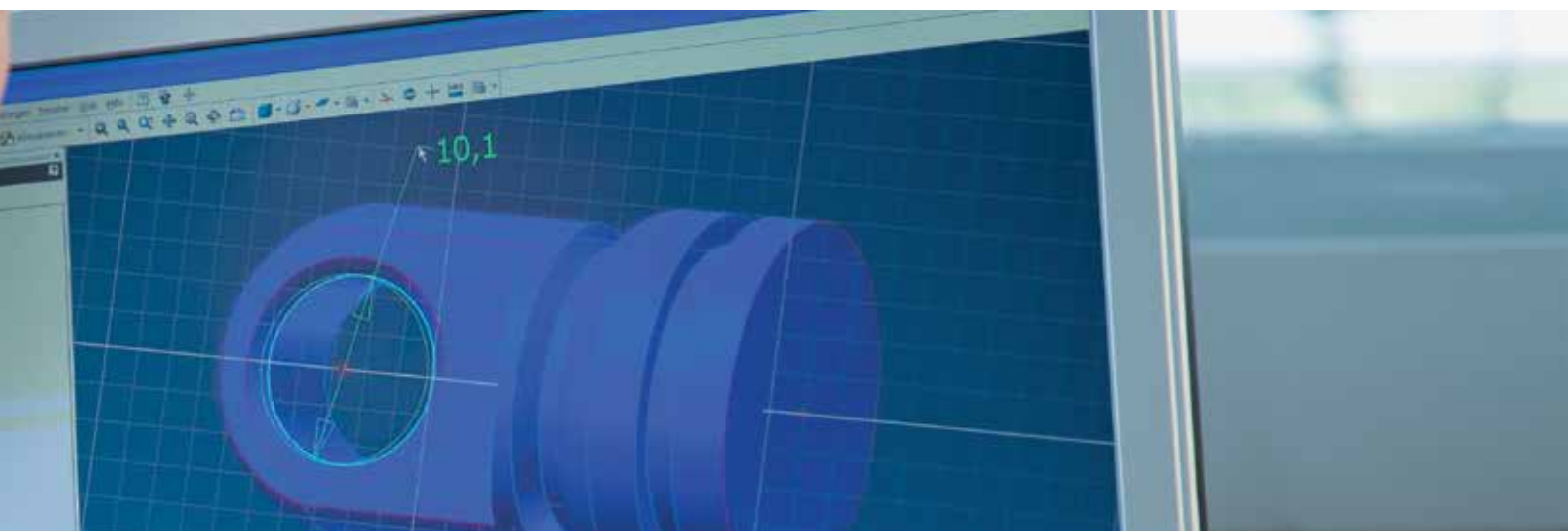

Thread rod	Thread cylinder	Extras	Steel	AISI 303/304	AISI 316L/316 Ti
M3.5	M3.5	–	•	–	•
M5	M5	4, 6, NT	•	•	•
M8	M8	2, 4, 6, NT, HT	•	•	•
M14x1.5	M14x1.5	4, 6	•	•	•
M14x1.5	M14x1.5	2, 6	•	•	o/r

Thread rod	Thread cylinder	Extras	Steel	AISI 303/304	AISI 316L/316 Ti
M8	M8	4, 6	•	o/r	o/r



Stabilus IndustryLine oil dampers are used for slowing down moving weights.

Oil dampers are closed, maintenance-free hydraulic elements which are used for the smooth slowing of feed units, linear drive units, flaps, etc.

Fixed dampers work in extension, compression or in both directions and can hold up from 50N to 2500N. All fixed dampers are available in different sizes in steel and stainless steel AISI 303/304 and AISI 316L/316Ti.

In addition to fixed oil dampers Stabilus IndustryLine also offers adjustable oil dampers. Adjustable dampers are used when the exact damping force needed is unknown. The damping force can be increased or decreased by turning the piston rod. So we always provide the perfect solution for your application.

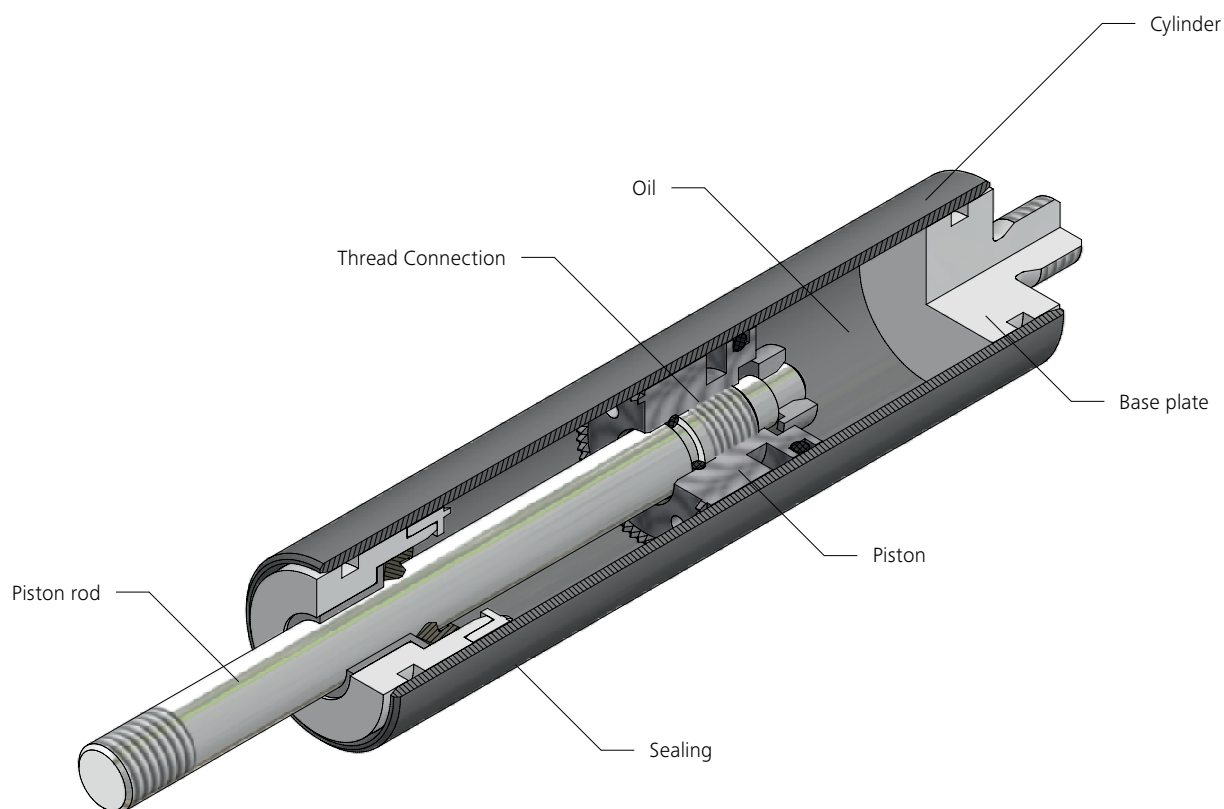

The special advantage of Stabilus IndustryLine gas springs is the solution of customer-specific tasks, for which we also develop unusual springs and products. The patent-protected double-stroke spring is an example of this.

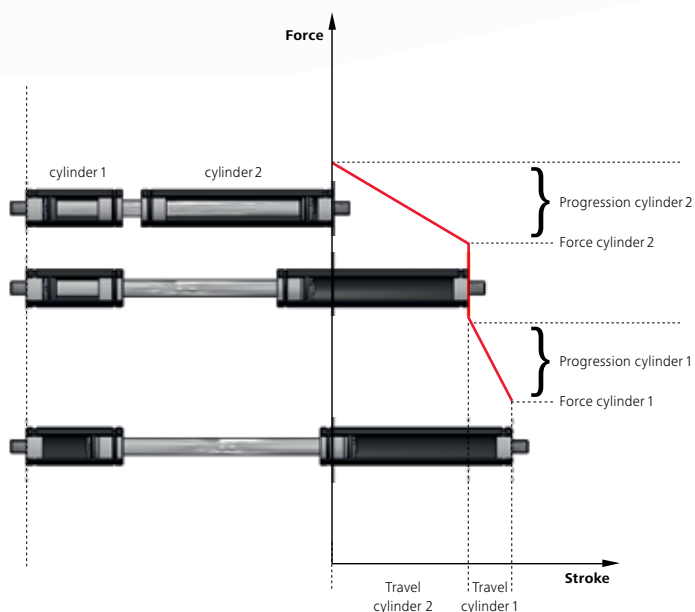

Hahn Gasfedern has developed special double-stroke springs for heavy flaps with a large opening angle, which are characterized by a low starting and a high ultimate force. These springs have two pressure cylinders that can be filled differently and thus are able to cover two force ranges. The compression of the piston rod generates a bent characteristic curve, which can be better adjusted to the force progression of the flap.

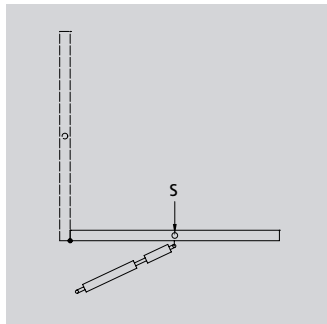

In this position, the point of gravity S is furthest away from the pivot point. The strongest force is required for opening the flap. Both strokes are compressed. The cylinder with the stronger force opens it.

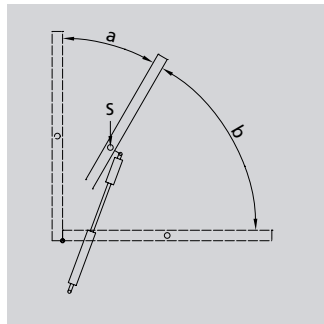

In this position, the point of gravity S moves closer to the pivot point. A weaker spring force is required. Stroke 1 is extended in this position. The spring part 2 with the weaker force now becomes effective.

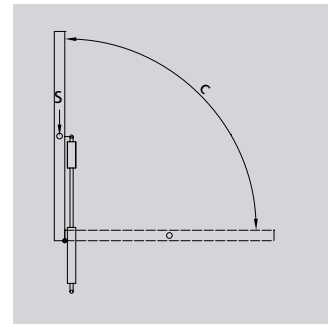

In this position, the point of gravity S is close to or directly on the pivot point. A weak spring force is required. Both strokes are fully extended.

Double-stroke springs are specially designed for the application you require. The force ranges are exactly attuned to each other and adapted to the required kinematics. Stabilus IndustryLine double-stroke springs are available in steel, AISI 303/304 and AISI 316L/316Ti.

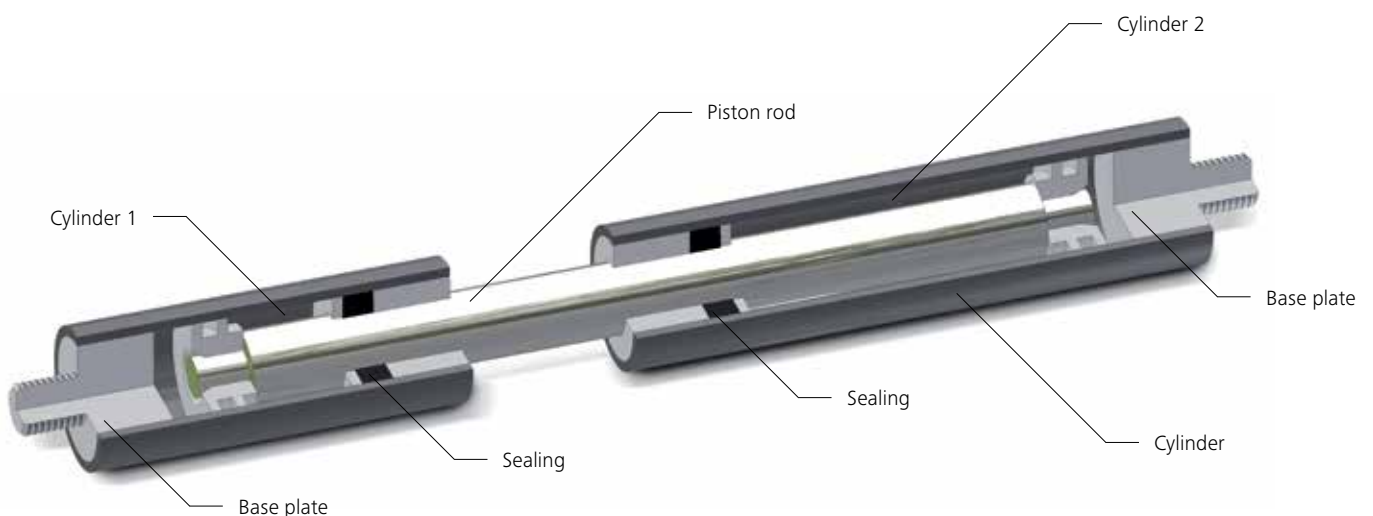

With a broad range of fittings, brackets and special accessories, the application options for Stabilus IndustryLine gas springs can be combined and extended in every possible way:



Various fittings such as fork heads, hinged eyelets, hinged joints etc. are suitable for all mounting applications in combination with the matching brackets for the product. Depending on the individual case, Stabilus IndustryLine supplies a variety of different fittings so that customers can select the best solutions from this intelligent modular system.

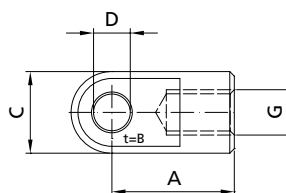

Eyelets

Type	Thread (G)	Installation length (A)	Thickness (B)	Width (C)	Cross hole Ø (D)	Steel	AISI 303/304	AISI 316L/316Ti	Plastic
AU 08	M2	8 mm	2,5 mm	4 mm	2.1 mm	•	–	–	–
AU 11	M3.5	11 mm	4 mm	8 mm	4.1 mm	•	–	–	–
AS 20	M5	20 mm	3 mm	12 mm	6.1 mm	•	•	–	–
AU 16	M5	16 mm	6 mm	10 mm	6.1 mm	•	•	•	–
AR 16	M5	16 mm	10 mm	15 mm	8.1 mm	•	–	–	–
AK 17	M8	17 mm	14 mm	14 mm	8.1 mm	–	–	–	•
AK 21	M8	21 mm	18 mm	18 mm	8.1 mm	–	–	–	•
AR 16	M8	16 mm	10 mm	15 mm	8.1 mm	•	–	–	–
AR 19	M8	19 mm	10 mm	15 mm	8.1 mm	•	–	–	–
AR 19	M8	19 mm	10 mm	15 mm	10.1 mm	•	–	–	–
AR 27	M8	27 mm	10 mm	15 mm	8.1 mm	•	–	–	–
AS 19	M8	19 mm	8 mm	14 mm	8.1 mm	•	–	–	–
AS 24	M8	24 mm	6 mm	14 mm	8.1 mm	•	–	–	–
AS 30	M8	30 mm	5 mm	18 mm	8.1 mm	•	–	–	–
AU 19	M8	19 mm	10 mm	14 mm	8.1 mm	•	•	•	–
AU 19	M8	19 mm	10 mm	14 mm	6.1 mm	•	–	–	–
AK 21	M10	21 mm	18 mm	18 mm	8.1 mm	–	–	–	•
AS 27	M10	27 mm	14 mm	18 mm	8.1 mm	•	–	–	–
AU 27	M10	27 mm	10 mm	18 mm	8.1 mm	•	•	•	–
AU 27	M10	27 mm	10 mm	18 mm	10.1 mm	•	•	•	–
AU 42	M14x1.5	42 mm	14 mm	25 mm	14.1 mm	•	•	•	–

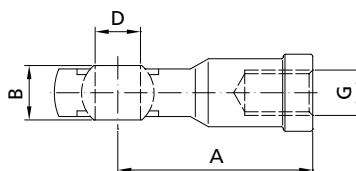

Hinged joints

Type	Thread (G)	Installation length (A)	Thickness (B)	Width	Cross hole Ø (D)	Steel	AISI 303/304	AISI 316L/316Ti	Plastic
AG 12	M2	12.5 mm	4 mm	–	2 mm	–	–	–	•
AG 27	M5	27 mm	8 mm	9 mm	5 mm	•	•	o/r	–
AG 36	M8	36 mm	12 mm	13 mm	8 mm	•	•	o/r	–
AG 43	M10	43 mm	14 mm	17 mm	10 mm	•	•	o/r	–
AG 57	M14x1.5	57 mm	19 mm	22 mm	14 mm	•	•	o/r	–

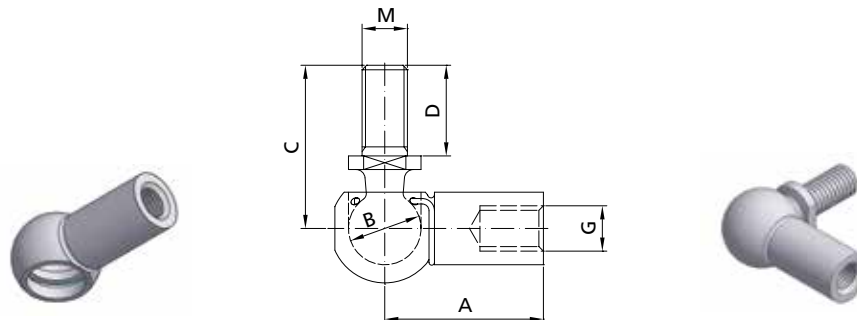

Ball joints and sockets

Type	Thread (G)	Installation length (A)	Socket diameter (B)	Bolt length (C)	Thread (MxD)	Steel	AISI 303/304	AISI 316L/316Ti
PF 12	M2	12.5 mm	4 mm	12.5 mm	-	•	-	-
WG 12	M2	12.5 mm	4 mm	12.5 mm	M2x7.5	•	-	-
PX 18	M3.5	18 mm	8 mm	-	-	•	-	-
WX 18	M3.5	18 mm	8 mm	19 mm	M4x10	•	-	-
PF 22	M5	22 mm	8 mm	-	-	•	o/r	o/r
PX 22	M5	22 mm	10 mm	-	-	•	-	-
WD 22	M5	22 mm	10 mm	19 mm	M8x12	•	-	-
WG 22	M5	22 mm	8 mm	19 mm	M5x10	•	•	•
WX 22	M5	22 mm	10 mm	23 mm	M8x12	•	•	-
WY 22	M5	22 mm	10 mm	23 mm	M6x12	•	-	-
PF 18	M8	18 mm	10 mm	-	-	•	-	-
PF 30	M8	30 mm	13 mm	-	-	•	o/r	o/r
WD 30	M8	30 mm	13 mm	29 mm	M8x16	•	-	-
WG 18	M8	18 mm	10 mm	23 mm	M8x12	•	•	-
WG 30	M8	30 mm	13 mm	29 mm	M8x16	•	•	•
WS 35	M8	35 mm	16 mm	36 mm	M10x20	•	-	-
WX 30	M8	30 mm	13 mm	29 mm	M10x16	•	-	-
PF 35	M10	35 mm	16 mm	-	-	•	-	-
WG 35	M10	35 mm	16 mm	36 mm	M10x20	•	•	•
WG 45	M14x1.5	45 mm	19 mm	48 mm	M14x28	•	•	•

ADKG

ADKU

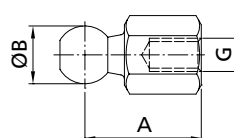
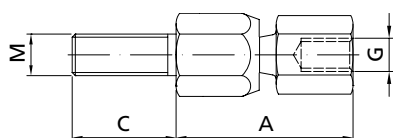

Axial joints

Type	Thread (G)	Installation length (A)	Ball diameter (B)	Bolt (MxC)	Steel	AISI 303/304	AISI 316L/316Ti
ADKG	M5	28 mm	8 mm	M8x35	•	-	-
ADKU	M5	20 mm	8 mm	-	•	-	-
ADKG	M8	31 mm	10 mm	M8x35	•	-	o/r
ADKU	M8	23 mm	10 mm	-	•	-	-
ADKG	M10	43 mm	14 mm	M10x25	•	-	o/r
ADKU	M10	28 mm	14 mm	-	•	-	-
ADKG	M14x1.5	56 mm	20 mm	M14x1.5x40	•	-	-
ADKU	M14x1.5	35 mm	20 mm	-	•	-	-

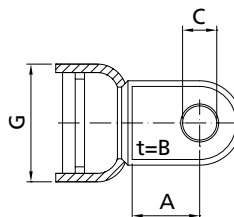

Base plate eyelet (for tube side)

Type	For cylinder Ø (G)	Installation length (A)	Thickness (B)	Cross hole Ø (C)	Steel	AISI 303/304	AISI 316L/316Ti
AB04	6 mm	4 mm	2.5 mm	2.1 mm	•	–	–
AB07	10 mm	7 mm	4 mm	4.1 mm	•	–	–
AB07	12 mm	7 mm	4 mm	4.1 mm	•	–	–
AB09	15 mm	9 mm	6 mm	6.1 mm	•	–	–
AB11	19 mm	11 mm	10 mm	6.1 mm	•	–	–
AB11	19 mm	11 mm	10 mm	8.1 mm	•	–	–
AB11	23 mm	11 mm	10 mm	8.1 mm	•	–	–
AB11	23 mm	11 mm	10 mm	10.1 mm	•	–	–
AB16	28 mm	16 mm	10 mm	8.1 mm	•	–	–
AB16	28 mm	16 mm	10 mm	10.1 mm	•	–	–
AZ20	40 mm	20 mm	14 mm	14.1 mm	•	•	–

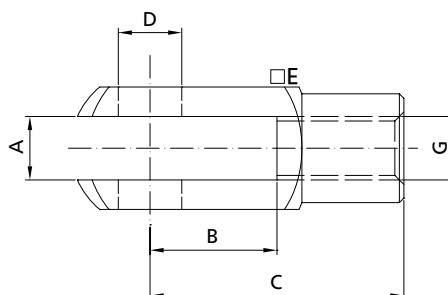

Forks

Type	Thread (G)	Size (AxB)	Installation length (C)	Width (E)	Bolt Ø (D)	Steel	AISI 303/304	AISI 316L/316Ti
GA16	M3.5	4x8 mm	16 mm	8 mm	4 mm	•	–	–
GG16*	M3.5	4x8 mm	16 mm	8 mm	4 mm	•	–	–
GA20	M5	5x10 mm	20 mm	10 mm	5 mm	•	•	–
GG20*	M5	5x10 mm	20 mm	10 mm	5 mm	•	•	•
GA32	M8	8x16 mm	32 mm	16 mm	8 mm	•	•	–
GG32*	M8	8x16 mm	32 mm	16 mm	8 mm	•	•	•
GS40	M8	10x20 mm	40 mm	20 mm	10 mm	•	–	–
GA40	M10	10x20 mm	40 mm	20 mm	10 mm	•	•	–
GG40*	M10	10x20 mm	40 mm	20 mm	10 mm	•	•	•
GS32	M10	8x16 mm	32 mm	16 mm	8 mm	•	–	–
GX32	M10x1	8x16 mm	32 mm	16 mm	8 mm	•	–	–
GA56	M14x1.5	14x28 mm	56 mm	27 mm	14 mm	•	•	–
GG56*	M14x1.5	14x28 mm	56 mm	27 mm	14 mm	•	•	•
GA80	M20	20x40 mm	80 mm	40 mm	20 mm	•	–	–
GA99	M24	25x50 mm	99 mm	50 mm	25 mm	•	–	–

* Fork joint steel with ES-bolts, AISI 303/304 with Ben bolts, AISI 316L/316Ti with eyebolts.

Depending on the size and material of your product, the fitting possibilities can also vary. Therefore, Stabilus IndustryLine offers a wide range of matching brackets.



BC01

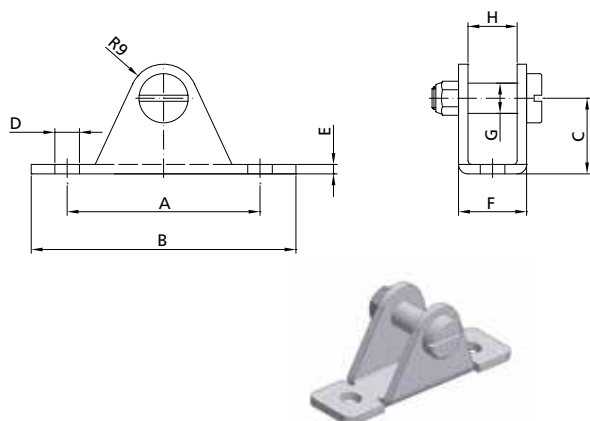

BC04

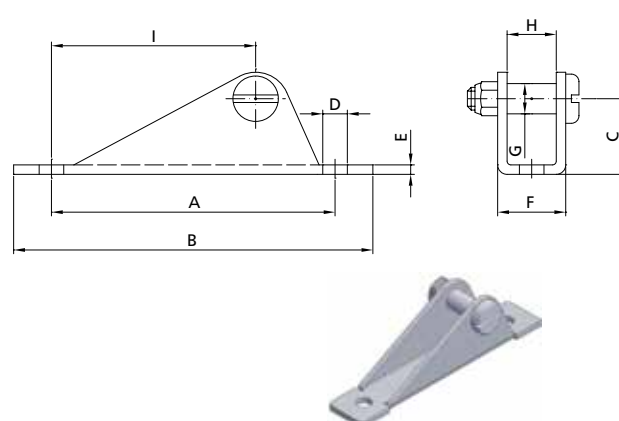

Clevis bracket

Type	A	B	C	D	E	F	G	H	I	Stability	Steel	AISI 316L/Ti
BC01	51 mm	70 mm	20 mm	6.5 mm	2.5 mm	18 mm	8 mm	13 mm	–	1800 N	•	•
BC04	75 mm	95 mm	20 mm	6.5 mm	2.5 mm	18 mm	8 mm	13 mm	54 mm	1800 N	•	•

BA20/K

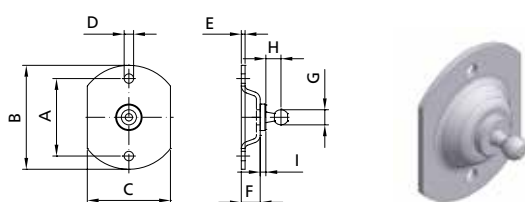

BA20/Z

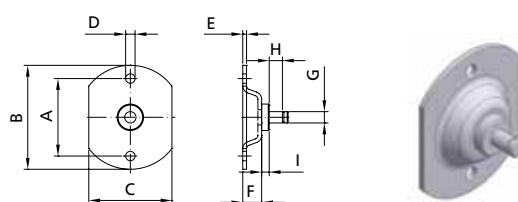

Round bracket

Type	A	B	C	D	E	F	G	H	I	Stability	Steel	AISI 316L/Ti
BA20/K08	41 mm	55 mm	44 mm	5.3 mm	2 mm	10 mm	8 mm	8 mm	3 mm	500 N	•	•
BA20/K10	41 mm	55 mm	44 mm	5.3 mm	2 mm	10 mm	10 mm	9 mm	3 mm	800 N	•	•
BA20/K13	41 mm	55 mm	44 mm	5.3 mm	2 mm	10 mm	13 mm	9.5 mm	3 mm	1200 N	•	•
BA20/Z06	41 mm	55 mm	44 mm	5.3 mm	2 mm	10 mm	6 mm	7 mm	4 mm	500 N	•	•
BA20/Z08	41 mm	55 mm	44 mm	5.3 mm	2 mm	10 mm	8 mm	11 mm	5 mm	1200 N	•	•

For optimum use and perfect force transmission, Stabilus IndustryLine offers a wide range of fittings and brackets. The examples shown are only a small excerpt from our product range. If required, we can also develop a tailor-made solution for you.



BA01/K

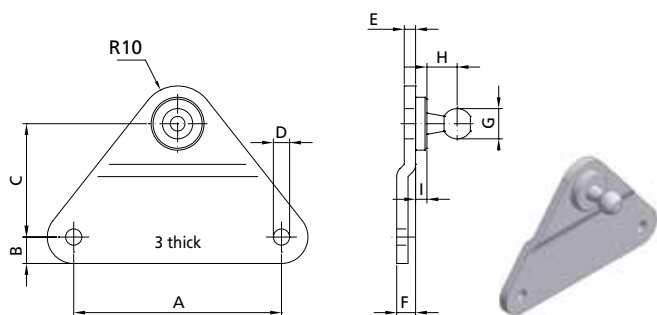

BA01/Z

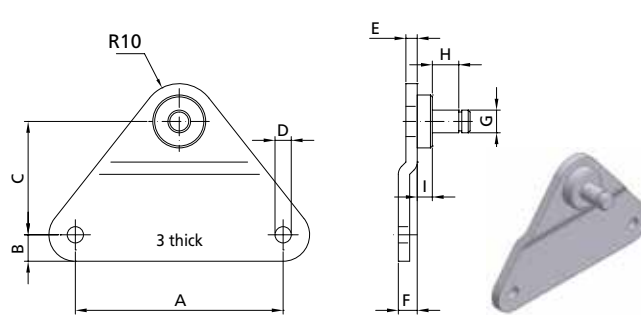

BB01/K

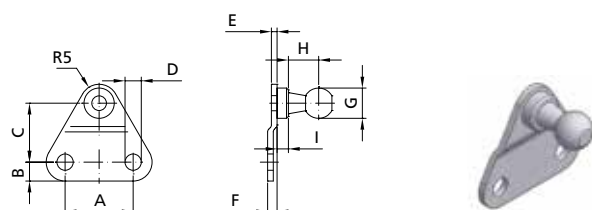

BB01/Z

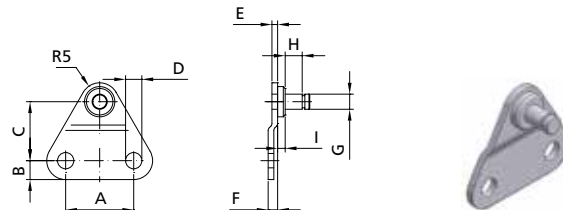

Side bracket

Type	A	B	C	D	E	F	G	H	I	Stability	Steel	AISI 316L/Ti
BB01/K08	18 mm	5 mm	15.5 mm	4.3 mm	1.5 mm	2.5 mm	8 mm	8 mm	3 mm	180 N	•	•
BB01/Z04	18 mm	5 mm	15.5 mm	4.3 mm	1.5 mm	2.5 mm	4 mm	4.5 mm	2 mm	180 N	•	•
BB01/Z06	18 mm	5 mm	15.5 mm	4.3 mm	1.5 mm	2.5 mm	6 mm	6.5 mm	4 mm	180 N	•	•
BA01/K08	55 mm	7 mm	30 mm	5.3 mm	3 mm	5 mm	8 mm	8 mm	3 mm	500 N	•	•
BA01/K10	55 mm	7 mm	30 mm	5.3 mm	3 mm	5 mm	10 mm	8 mm	3 mm	800 N	•	•
BA01/K13	55 mm	7 mm	30 mm	5.3 mm	3 mm	5 mm	13 mm	9.5 mm	3 mm	1200 N	•	•
BA01/Z06	55 mm	7 mm	30 mm	5.3 mm	3 mm	5 mm	6 mm	7 mm	4 mm	500 N	•	•
BA01/Z08	55 mm	7 mm	30 mm	5.3 mm	3 mm	5 mm	8 mm	11 mm	5 mm	1200 N	•	•



BA30/K

BA30/Z

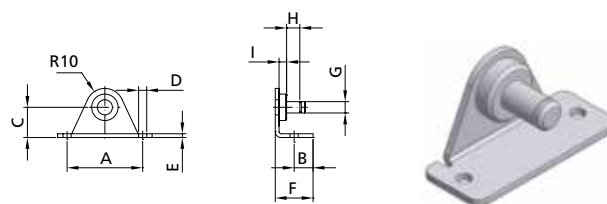
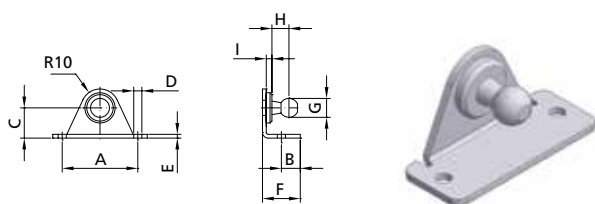

BB20/K

BB20/Z

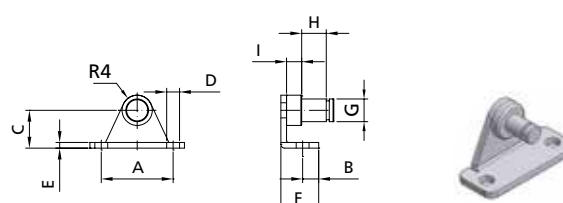
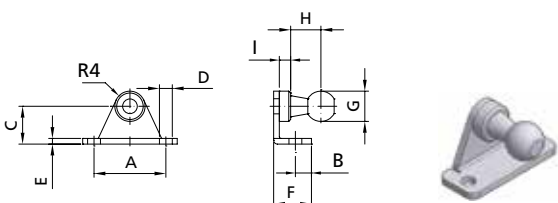

Angular bracket

Type	A	B	C	D	E	F	G	H	I	Stability	Steel	AISI 316L/Ti
BB20/K08	19 mm	4.25 mm	10 mm	3.4 mm	1.5 mm	10 mm	8 mm	8 mm	3 mm	180 N	•	•
BB20/Z04	19 mm	4.25 mm	10 mm	3.4 mm	1.5 mm	10 mm	4 mm	4,5 mm	2 mm	180 N	•	•
BB20/Z06	19 mm	4.25 mm	10 mm	3.4 mm	1.5 mm	10 mm	6 mm	7 mm	4 mm	180 N	•	•
BA30/K08	40 mm	10 mm	16 mm	5.3 mm	2 mm	20 mm	8 mm	8 mm	3 mm	500 N	•	•
BA30/K10	40 mm	10 mm	16 mm	5.3 mm	2 mm	20 mm	10 mm	9 mm	3 mm	800 N	•	•
BA30/K13	40 mm	10 mm	16 mm	5.3 mm	2 mm	20 mm	13 mm	9.5 mm	3 mm	1200 N	•	•
BA30/Z06	40 mm	10 mm	16 mm	5.3 mm	2 mm	20 mm	6 mm	7 mm	4 mm	500 N	•	•
BA30/Z08	40 mm	10 mm	16 mm	5.3 mm	2 mm	20 mm	8 mm	11 mm	5 mm	1200 N	•	•

With special protection tubes, locking devices and other extras, Stabilus IndustryLine gas springs can also be used in difficult environments. For even more extreme conditions, our specialists and technicians develop intelligent solutions that meet virtually every requirement.

1 – Wiper ring

The wiper ring prevents foreign matter from entering into the gas springs.

2 – Radial valve

Via the radial valve, the force of the gas spring can be adjusted when it is built in. Radial valves need to be considered when calculating the length of the gas spring (GL).

4 – Grease chamber

Permanent lubrication of the piston rod; thus lower friction forces and installation of the gas spring independent of the position. When designing the gas spring, a reduction in the usable stroke needs to be considered.

5 – Valve

The valve allows the force of the gas spring to be adjusted. In the gas spring, it is located at the threaded pin of the base plate; in the tension spring, it is designed as a valve section on the piston rod.

6 – Protection tube

Protects the piston rod from mechanical damage. Reduces the risk of bending for long strokes

7 – Floating piston

Oil-hydraulic damping along the entire stroke, independent of the installation position

8 – Locking device

Mechanical locking for extended piston rod. The locking device needs to be considered when calculating the length of the gas spring (GL).

B3 – Sealing system

For gas springs with high forces and increased wear, e.g. for use in building machines. Allows an installation of the gas spring independent of the position. When designing the gas spring, a reduction in the usable stroke needs to be considered.

NT – Low-temperature design

For use of gas springs at an ambient temperature of up to -40°C . Allows installation of the gas spring independent of the position. When designing the gas spring, a reduction in the usable stroke needs to be considered.

HT – High-temperature design

For use of gas springs at an ambient temperature of up to 200°C . Allows installation of the gas spring independent of the position. When designing the gas spring, a reduction in the usable stroke needs to be considered.

RK – Friction element

Increases the friction force for gas springs for the secure positioning of windows, skylights, etc.

Must be observed prior to mounting, construction or storage!

1. If gas springs, tension springs or dampers are used in environments where a failure of the product can lead to damage to persons and/or material damage, additional security elements must be applied. When installing/removing gas springs or tension springs, accident prevention measures must always be kept in mind. Stabilus IndustryLine products may only be used in the aviation, aerospace and shipping industry with written authorisation of Stabilus GmbH.
2. Installation + storage of the products: Gas springs must be stored with the piston rod pointing downwards, tension springs with the piston rod upwards, dampers with the piston rod downwards. Pressure losses as a result of storage according to the instructions are not to be expected; however, the products should not be stored for longer than 6 months. When using the products for the first time (compression/extension of the piston rod) after longer periods of non-use, it is possible that a sticking effect (slip-stick effect) occurs; therefore, stronger forces are required to compress or extend the piston rod. Prior to installing the products, the film tubing must be removed.
3. Gas springs, tension springs and dampers are not safety parts. Gas springs, tension springs and dampers are wear parts and thus must be replaced depending on the stress applied and the area of application. They must be particularly protected from corrosion in order to increase their lifetime and durability. Small amounts of hydraulic oil can escape from the products; these must not come into contact with food or ground water.
4. Filling of the products is only allowed with written authorisation of Stabilus GmbH.
5. Do not open – high pressure! Do not heat to more than 80 °C!
6. Make sure there is sufficient play in the cylinder hook-ups, i.e. avoid rigid installation. If required, lubricate cylinder hook-ups in order to achieve lower friction forces and an increased lifetime of the fittings.
7. Screwed-on fittings (lugs etc.) must be screwed in completely and rest firmly on the face if required. Possibly loose fittings must be screwed on completely prior to installation. Should vibrations occur, the fittings must be secured against twisting (by gluing in).
8. Make sure the piston rod does not get jammed (for long strokes/products, an additional bearing/guide must be provided for the product; sagging, bending or kinking must be avoided).
9. Only axial loads are permissible (risk of kinking!). Cross or torsion forces must not occur.
10. Gas springs must not be stressed on extension, tension springs not on compression.
11. Gas springs, tension springs as well as dampers may be used as end brackets if the nominal force +30% is not exceeded (no overstretching or jarring of the product), i.e. the products may only be loaded with their nominal force +30% on compression or tension. Mechanical brackets should particularly be applied in addition in case of strong forces in order to rule out a jarring or overstretching of the product.
12. Temperature range for use -20 °C to +80 °C. For use in temperatures below 0 °C, we kindly ask you to specify this. In case of temperature variations, the compression or tension forces of the products also change. The viscosity of the oil also changes if temperatures vary. (Change of the damping behaviour, particularly for dampers)
13. Small damage, corrosion or paint residues on the piston rod lead to a failure of the spring (sealings are damaged). The cylinder tube must not be damaged or deformed. Generally, all changes to the product made by third parties result in an exclusion of warranty.
14. Tension springs are open systems, i.e. it must be avoided that dirt or other media get into the tension springs through the ventilation hole at the cylinder end. (Installation with the piston rod pointing upwards). During installation, it is necessary to make sure that the tension springs are not installed in closed systems but in ventilated systems, in which condensate cannot develop due to temperature variations.
15. Locking gas springs have a tube as the piston rod, which contains a release pin. It is necessary to prevent foreign media such as dirt or cleaning agents from getting into the piston rod hole. This can lead to corrosion in the piston rod and cause the release pin to get wedged. Preferentially, the locking gas springs should be installed with the piston rod pointing downwards. If locking gas springs are used in environments where they get into contact with cleaning agents (hospital beds), this generally must be specified. Maximum number of release activities approx. 30,000.
16. Warranty is excluded for any installation suggestions/drawings for gas springs, tension springs and dampers. It must be considered that not all installation parameters can be included in the theoretical suggestion; therefore, the installation must be carried out with utmost care in practice, since friction values or accelerations cannot or can only roughly be considered in the theoretical suggestion.
17. The installation or use of gas springs or tension springs should generally be tested by the user under operating conditions, since the operating or installation conditions are very varied and thus not all parameters can be simulated or tested at Stabilus IndustryLine. It is generally necessary to specify whether the products are used under normal conditions (20 °C, natural environment = air) or whether foreign media (e.g. water vapour >80 °C, diverse chemicals, cleaning agents) impact on them.

Tolerances/characteristics/disposal

1. Maximum pressure = 160 bars (20 °C)
2. Maximum stroke speed = 300 mm/s in installed state.
Attention: High stroke speeds or stroke frequencies lead to an overheating and thus to damage to the sealings and the failure of the product. High stroke speeds or accelerations must not lead to an overload of the product.
3. Length tolerance of the products = +/-2 mm
4. The tolerance for compression or tension forces generally is: (exact values in our testing instructions) minimum +/-3 Newton +/-5% of the nominal force; maximum +/-10% of the nominal force (20 °C). The nominal force is measured statically at extending stroke (for tension springs, at compressing stroke) 5 mm before stroke end (standard). Release force for pushing in the release pin for locking gas springs: approx. 18% of the nominal force F1 of the gas spring.
5. Lifetime: Depending on the function, the series and the stroke of the gas spring, a lifetime of more than 50,000 load changes is possible. Environmental influences and the installation situation can significantly reduce the lifetime. You can obtain further information on the lifetime of the spring you have selected from our technology department.
6. Disposal: Dampers, gas springs and tension springs are under pressure. They must not be opened or heated up. The products may only be opened according to the instructions by Stabilus GmbH (on request, you can obtain them by post). All products have an oil filling; this must be disposed of according to the Waste Management Law.

Warranty is excluded for any non-observance of the above instructions.

Stabilus GmbH
Wallerheimer Weg 100
56070 Koblenz
Germany
info@stabilusindustryline.com
www.stabilusindustryline.com