

## Condition Monitoring Unit CMU 1000

Programmable

8 analogue inputs

### Ethernet interface

#### Description:

The CMU 1000 is an electronic evaluation unit designed for permanent online condition monitoring of machines and systems. In order to achieve this, the device must be supplied with relevant data which is recorded by the sensors connected to it.

This recorded data (processed or unprocessed) can be transferred by the CMU 1000 via different interfaces or as an analogue value to other devices and/or monitoring levels.

The CMU 1000 processes the application program stored in it continuously and cyclically like a PLC. The user creates this program simply and conveniently on a PC using the **CM Editor** developed for this purpose and then uploads it to the CMU 1000.

The **CM Editor** is part of the HYDAC PC software **CMWIN Version V03 or higher** (supplied) and it provides the various tools and functions in accordance with IEC 61131 for designing, integrating and testing the user program using "drag and drop" operations. The device is equipped with a background-lit LCD display as well as three different-coloured LEDs for the status display and presentation of messages and values. The CMU 1000 is operated and data is input on site using a built-in key pad within the menu structure of the device. The CMU 1000 is designed for use in machines in both the stationary and mobile sectors. It is possible to connect easily to higher-level control, monitoring and bus systems using the built-in interfaces or in combination with an additional coupling module.

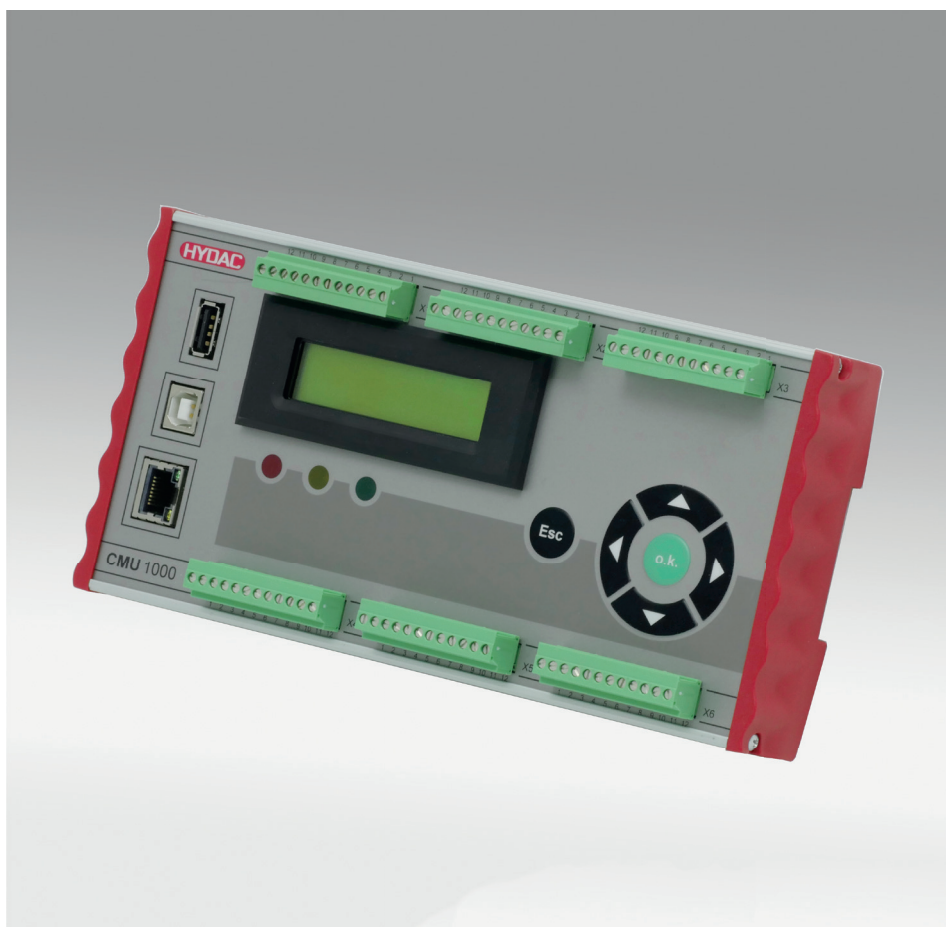

#### Special features:

- 8 input channels for HSI or SMART sensors
- 8 input channels for analogue sensors
- 4 input channels for digital signals
- 2 output channels for analogue signals
- 4 relay switching outputs with changeover contacts
- USB slave interface for PC connection
- USB Master interface for storing the measured data on a commercially available USB memory stick.
- Ethernet interface
- RS 232 interface
- 2-line LCD display (2 x 16 characters) for display of measured data and status and/or error messages
- 3 freely programmable, different-coloured LEDs for status display (red, yellow, green)
- Simple operation via navigation cross
- Creation of customised application programs using the PC software CMWIN supplied

## Technical data:

Supply	
Input voltage	18.0 .. 35.0 V DC
Current consumption	max. 1.5 A
Reverse polarity protection	-30 V
Insulation voltage	+40 V
Connection of sensors	Up to 8 sensors with HSI functionality or up to 8 SMART sensors <sup>1)</sup> and in addition up to 8 analogue sensors and up to 4 digital sensors 4 x digital / 2 x digital + 2 x frequency / 3 x digital + 1 x frequency
Analogue inputs	
Channels I and J (accuracy)	4 .. 20 mA ( $\leq \pm 0.1$ % FS max.) 0 .. 20 mA ( $\leq \pm 0.1$ % FS max.) 0.5 .. 4.5 V ( $\leq \pm 0.1$ % FS max.) 0 .. 10 V ( $\leq \pm 0.1$ % FS max.)
Channels K and L (accuracy)	4 .. 20 mA ( $\leq \pm 0.1$ % FS max.) 0 .. 20 mA ( $\leq \pm 0.1$ % FS max.) 0.5 .. 4.5 V ( $\leq \pm 0.1$ % FS max.) 0 .. 50 V ( $\leq \pm 0.1$ % FS max.) -10 .. +10 V ( $\leq \pm 0.2$ % FS max.) L only!
Channels M and N (accuracy)	4 .. 20 mA ( $\leq \pm 0.1$ % FS max.) 0 .. 20 mA ( $\leq \pm 0.1$ % FS max.) 0.5 .. 4.5 V ( $\leq \pm 0.1$ % FS max.)
Channels O and P (accuracy)	4 .. 20 mA ( $\leq \pm 0.1$ % FS max.) 0 .. 20 mA ( $\leq \pm 0.1$ % FS max.) 0.5 .. 4.5 V ( $\leq \pm 0.1$ % FS max.) -10 .. +10 V ( $\leq \pm 0.2$ % FS max.) P only!
Digital inputs	
Quantity	4, of which 2 are for frequency measurements (channels Q and R)
Trigger threshold	approx. 2 V
Dynamics	30 kHz
Measurement channels	
Quantity	32 – one measurement channel can be a value of a connected sensor (also a subchannel of a SMART sensor) or a value derived (calculated) from sensor data.
Analogue outputs	
Quantity	2
Type	Individually selectable, current (4 .. 20 mA) or voltage (0 .. 10 V)
Digital outputs	
Quantity	4
Type	Relay output, change-over contact
Switching capacity	30 V DC / 1 A
Calculation unit	
Analogue value recording	12 bit A/D converter

Note: <sup>1)</sup> SMART sensors (Condition Monitoring Sensors) are a generation of sensors from HYDAC which can provide a variety of different measured values.

Interfaces	
Keypad	<ul style="list-style-type: none"> <li>● 4 arrow keys (up, down, right, left)</li> <li>● OK key</li> <li>● ESC key</li> </ul>
Display (with LED backlight)	<ul style="list-style-type: none"> <li>● Two-line LCD display (2 x 16 characters)</li> <li>● Additional display of status information via 3 different-coloured LEDs possible</li> </ul>
USB mass storage device <sup>2)</sup>	<ul style="list-style-type: none"> <li>● USB 1.1 / USB 2.0 full speed interface for connection of a mass storage device (memory stick)</li> <li>● Female connection type "A".</li> </ul>
Ethernet, supported protocols	<ul style="list-style-type: none"> <li>● RJ 45 8/8 Ethernet interface</li> <li>● HTTP Server</li> <li>● TCP/IP</li> </ul>
Serial Interface 0 (UART 0)	<ul style="list-style-type: none"> <li>● Implementing an RS 232 or an HSI master interface</li> <li>● Change-over user-programmable</li> <li>● Connection via plug-in terminals</li> <li>● No handshake lines</li> </ul>
HSI Master	Cascading the CMU
USB device	<ul style="list-style-type: none"> <li>● USB 1.1 / USB 2.0 full speed interface for connecting a PC/laptop for configuration of the CMU</li> <li>● Female connection type "B".</li> </ul>

### Cycle time

Determined independantly at program start  
Current cycle time can be displayed in CM Editor

### Operating and environmental conditions

Operating temperature	-20 .. +70 °C
Storage temperature	-30 .. +80 °C
Relative humidity	0 .. 70 %, non-condensing

### Dimensions and weight

Dimensions	approx. 212 x 106 x 36 mm
Weight	approx. 600 g

### Technical standards

EMC	EN 61000-6-1 / 2 / 3 / 4
Safety	EN 61010
Protection class	IP 40

Note.: <sup>2)</sup> Recorded data from the CMU can be transferred to a memory stick via this interface. The USB host supports exclusively mass storage devices.

## CM Editor:

The CM Editor is part of the HYDAC PC software **CMWIN**, Version 03 or higher, and provides a wide variety of tools and functions for designing, integrating and testing the application program. An application program consists of many individual functions which can be linked together. During subsequent operation, this user program is processed as for a PLC, cyclically. The program is created according to the IEC 61131 (the standard for PLC programming).

The screenshot shows the CM Editor interface with a central workspace for 'Linked functions'. The workspace contains a ladder logic diagram starting with a 'Start' button, followed by a pulse generator, a comparison function ( $\geq 1$ ), and several 'Setzen Text' (Set Text) functions connected to 'Text' outputs. The left sidebar shows 'Function properties' for 'Input1' and a 'Function list' with various logic functions. The right sidebar contains a 'Functions' palette with categories like 'Data sources', 'Calculations', 'Numerical operations', 'Conditions', 'Links', 'Boolean operations', and 'Result values/actions'.

This screenshot shows the 'File' menu with options: Display, Simulate, Transfer into device, Receive from device, Deleting in the device, and Online debugging. The 'Simulate' option is highlighted.

This screenshot shows a context menu for a device with options: Apply from file, Apply from device, Uninstall, Saving to a file..., and Display.

The 'Simulation' window displays a table of sources and actions. The 'Sources' table has columns for Name, Input value, and Cycle. The 'Actions' table has columns for Name, Value, Cycle, and Time.

Sources		Actions		
Name	Input value	Name	Value	Cycle
Eingabe2	1	Aktion1	not triggered	
Input1	1	Aktion17	not triggered	
		Aktion18	not triggered	
		Aktion19	not triggered	

Cycle: 0

The 'CM Program - Programm CMU 1000-4\_Eng' window shows a list of variables and their assigned functions:

- Eingabe2: Boolean input value(;1;"Start 2";
- Input1: Boolean input value(;1;"Start";0
- Intervall1: Time sensor(1)
- Pulse generation1: Pulse generation(Input1)
- Flankenerkennung?: Pulse generation(Eingabe2?)

## Block circuit diagram:

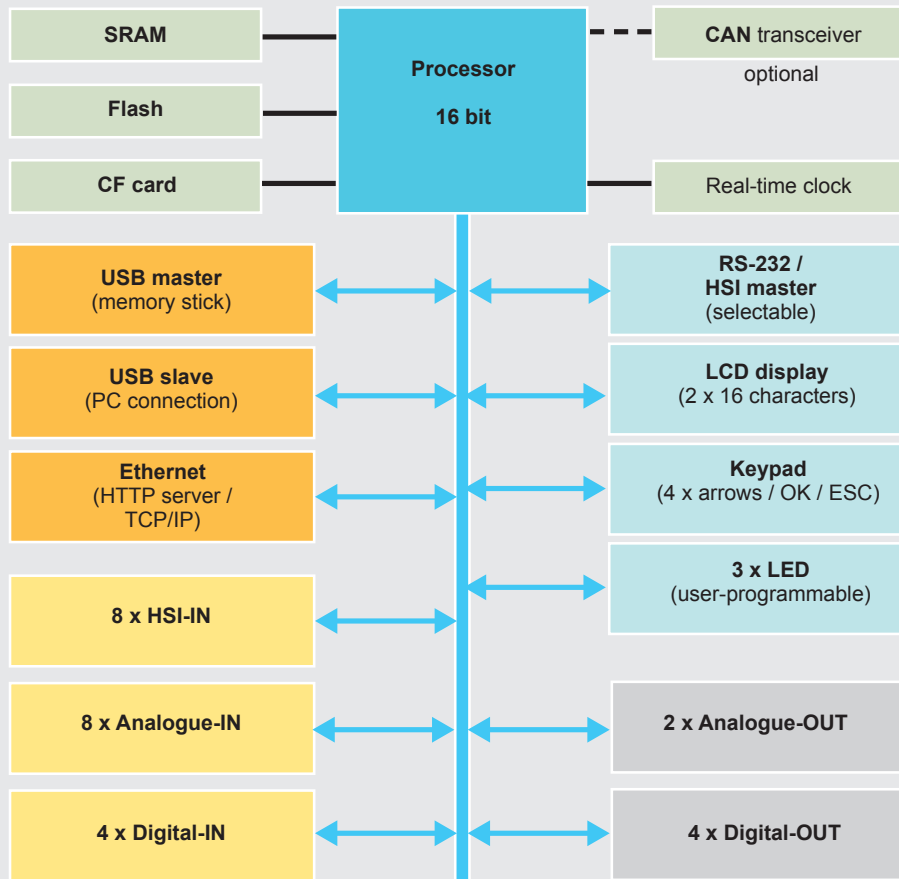

## Dimensions:

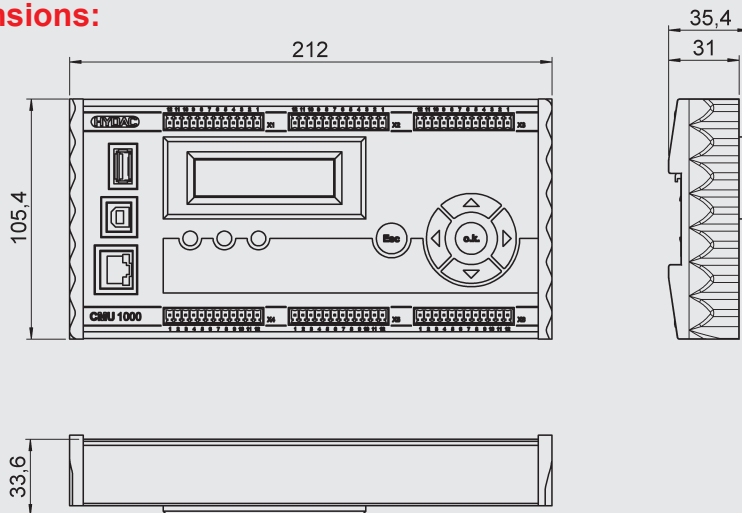

## Note:

The information in this brochure relates to the operating conditions and applications described.

For applications or operating conditions not described, please contact the relevant technical department.

Subject to technical modifications.

## Model code:

**CMU 1000 – 000 – X**

### Modification number

000 = standard

### User interface and documentation

D = German  
E = English  
F = French

### Accessories:

Appropriate accessories, such as sensor lines for the electrical connection, can be found in the Accessories brochure.

### HYDAC ELECTRONIC GMBH

Hauptstraße 27, 66128 Saarbrücken  
Germany  
Telephone +49 (0)6897 509-01  
Fax +49 (0)6897 509-1726  
E-mail: [electronic@hydac.com](mailto:electronic@hydac.com)  
Internet: [www.hydac.com](http://www.hydac.com)