



Contamination Sensor Module Economy CSM-E

Description

The Contamination Sensor Module CSM Economy 1000 is a compact and cost-effective online Condition Monitoring module for conditioning hydraulic and lubricating fluids as well as Diesel fuels (CSM-E 1xxx-4). It is used together with the fluid sensors (available separately) to measure solid particle contamination, water saturation and oil degradation.

The CSM Economy consists of a motor, pump, air bubble suppression and sensor connection block and can also be combined with the fluid sensors of the series CS 1000, AS 1000 or AS 3000 and HLB 1400.

In addition, the optional CSI-C-11 data storage and network communication module allows the CMS-E to be expanded to a compact fluid condition monitoring solution.

Applications

- Monitoring of lubrication oil systems in paper industry, steel industry and energy sector
- Monitoring of Diesel in fuel tanks
- Monitoring of component cleanliness in test rigs
- Monitoring of oil cleanliness in tanks and pressure lines
- When no pressure is present at the measurement point
- As a tool for preventative, proactive preparation of maintenance work

Advantages

- Modular, cost-effective system for flexible combination with various fluid sensors
 - ContaminationSensor CS1000 for measuring the solid particle contamination
 - AquaSensor AS1000 or AS3000 for measuring the water saturation
 - HydacLab HLB 1400 for determining the fluid condition
- Also available for pumps with high inlet pressures

Technical data

Hydraulic data	CSM-E 1xxx-1	CSM-E 1xxx-2	CSM-E 1xxx-4
Operating pressure, maximum			
P _{IN} (INLET)	-0.4 to 0.5 bar	0.4 to 120 bar	-0.4 to 80 bar
P _{OUT} (OUTLET)	5 bar	5 bar	5 bar
Leak oil (LEAK)	-	0.5 bar	-
Hydraulic connectors			
P _{IN} (INLET)	G ¼ acc. ISO 228-1	G ¼ acc. ISO 228-1	G ¼ acc. ISO 228-1
P _{OUT} (OUTLET)	G ¼ acc. ISO 228-1	G ¼ acc. ISO 228-1	G ¼ acc. ISO 228-1
Leak oil (LEAK)	-	G ¼ acc. ISO 228-1	-
Permissible viscosity range for operation	10-3000 mm ² /s	10-3000 mm ² /s	2-1000 mm ² /s
Permitted viscosity range for measurement operation	10-1000 mm ² /s	10-1000 mm ² /s	2-800 mm ² /s
Flow rate (at 1500 rpm)	~ 100 ml/min	~ 180 ml/min	~ 280 ml/min
Permissible fluids	Hydraulic and lubrication fluids based on mineral oil		Diesel fuels
Pump type	Gear pump		
Suction height	Maximum 0.5 m		
Fluid temperature range	0 ... 85 °C		
Electrical data			
Power consumption	180 W @ 50 Hz 210 W @ 60 Hz		
Protection class	IP55		
General data			
Dimensions (without sensors and accessories)	256 x 262 x 189 mm (with connection block for CS 1000 and AS 1000 / AS 3000) 259 x 268 x 189 mm (with connection block for CS 1000 and AS 1000 / AS 3000)		
Empty weight	~ 12 kg including sensors		
Ambient temperature range	0 ... 40 °C		
Storage temperature range	-40 ... 80 °C		
Relative humidity	maximum 90 %, non-condensing		

Model code

CSM-E - 1 0 0 0 - 1 - Z - W/N/X60/O60 /-

Type

CSM-E = ContaminationSensor Module – Economy

Series

1 = for CS1000 with flange connection

Connection block

0 = prepared for AS1000/AS3000
1 = prepared for HydacLab HLB 1400

Version

0 = Standard

Fluids

0 = Mineral oil

Hydraulic version

1 = Gear pump, standard
2 = Gear pump, inlet pressure-stability with drain line
4 = Gear pump, magnetically coupled, inlet pressure-stability without drain line

Sensors

Z = without

Supply voltage

W/N/X60/O60 = 230V, 50 Hz, 3 Ph / 265V, 60 Hz, 3 Ph
400V, 50 Hz, 3 Ph / 460V, 60 Hz, 3 Ph

Supplementary details

- = without

Scope of delivery

- CSM-E, ready for connection (without sensors)
- Installation and Maintenance Instructions
- 4 fastening screws for the CS

Suitable sensors

The following sensors are suitable for use on the CSM-E.

ContaminationSensor CS1000

Model code	Part no.
CS1210-A-x-x-x-1/-000	3314212
CS1210-B-x-x-x-1/-000	3308284
CS1220-A-x-x-x-1/-000	3237730
CS1220-B-x-x-x-1/-000	3313779
CS1310-A-x-x-x-1/-000	3336820
CS1320-A-x-x-x-1/-000	3332066
CS1320-B-x-x-x-1/-000	3381031

AquaSensor AS1000

Model code	Part no.
AS1008-C-000	909109

AquaSensor AS3000

Model code	Part no.
AS3008-5-000	922591

HydacLab HLB 1400

Model code	Part no.
HLB14J8-1C000-000	923684
HLB14J8-00S12-000	923685

Hydraulic connectors

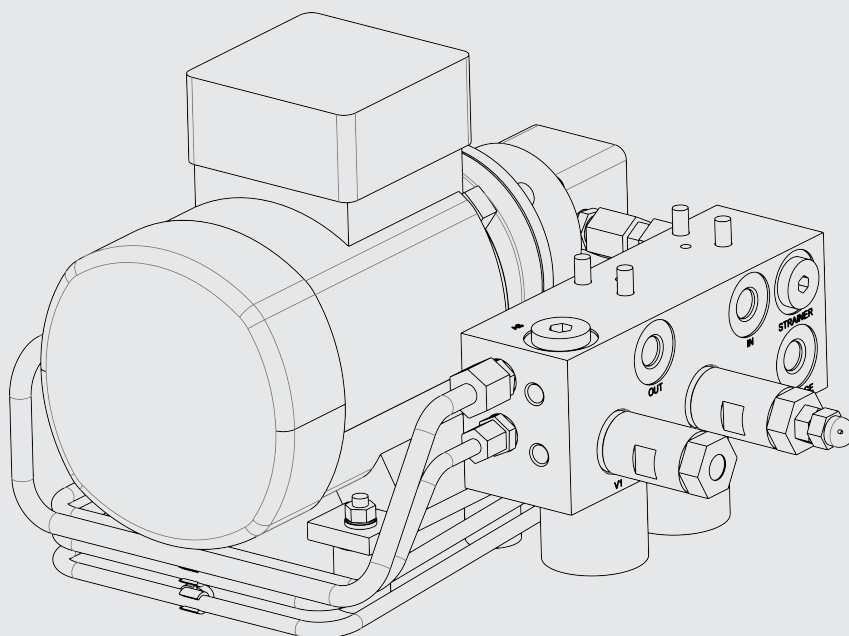

IN = Inlet
OUT = Outlet
LEAK = Drain port (optional depending on the pump)

Scope of delivery without sensors;

Illustration shows CSM-E without sensors and data communication module CSI-C-11

Hydraulic diagramm

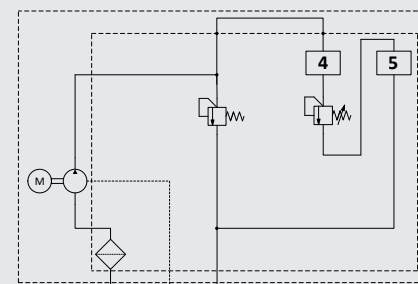

Position	Designation
1	Inlet (IN)
2	Outlet (OUT)
3	Leakage (LEAK)
4	ContaminationSensor CS
5	AquaSensor AS or HydacLab HLB

DIMENSIONS

CSM-E with CS1000, AS1000 and CSI-C-11

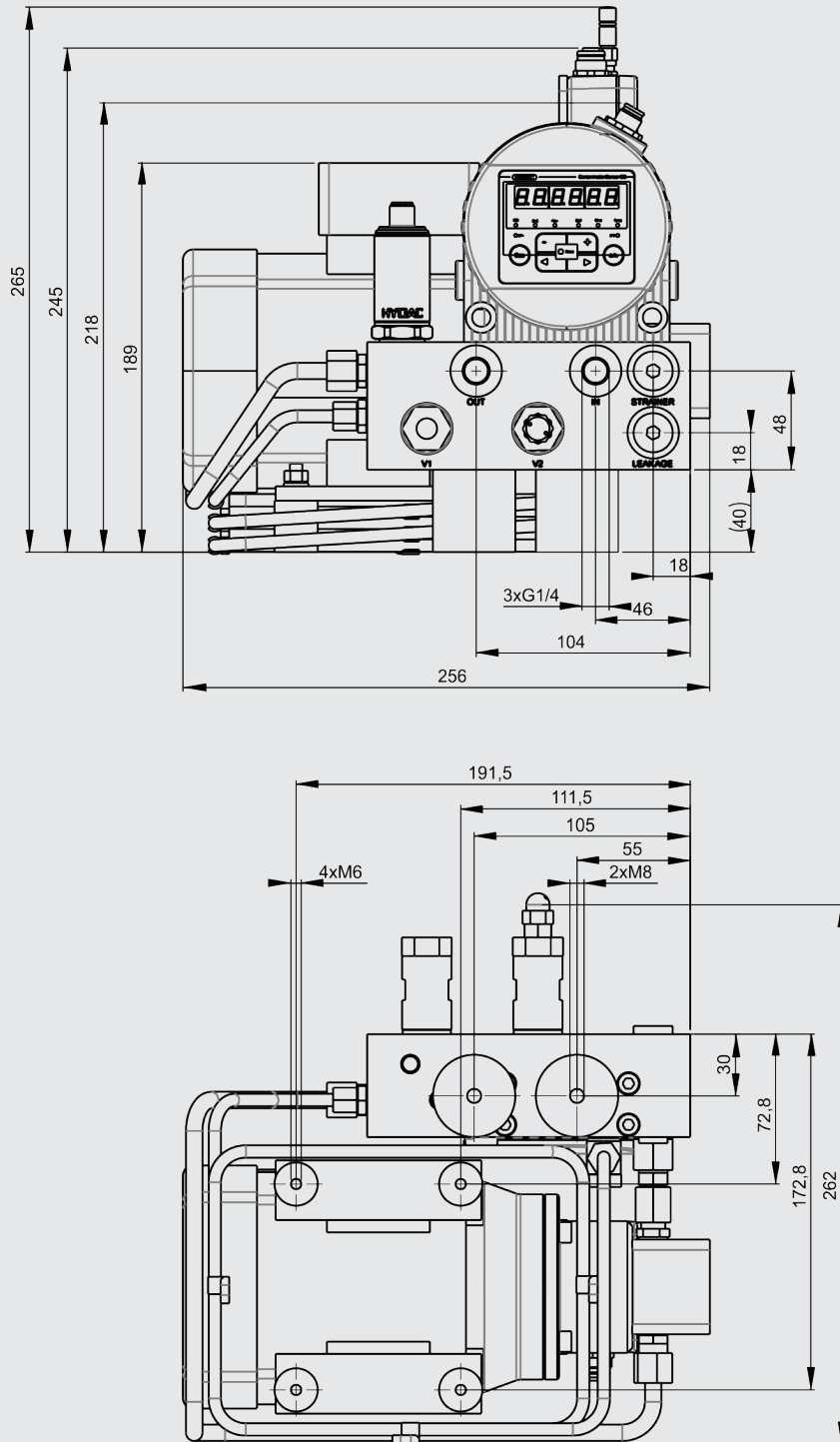

All dimensions in mm

(Scope of delivery without sensors)

Accessories

ContaminationSensor CS1000

Designation	Part no.
CD FluMoS light	3141522
CD FluMoS Professional	3355176
CD FluMoT, driver package	3355177
ZBE42S-02 socket plug (female) 8-pole with cable, length = 2 m	3281220
ZBE42S-05 socket plug (female) 8-pole with cable, length = 5 m	3281239
ZBE43-05 extension cable, coupling / plug 8-pole, length = 5 m	3281240
ZBE43-10 extension cable, coupling / plug 8-pole, length = 10 m	3519768
ZBE44 socket plug (female) 8-pole, shielded, with screw terminals	3281243
ZBE44 socket plug (female) 8-pin, shielded, with screw terminals	4193544

AquaSensor AS

Designation	Part no.
ZBE08S-02 socket plug (female) 5-pole, bent, with cable, length = 2 m	6019455
ZBE08S-05 socket plug (female) 5-pole, bent, with cable, length = 5 m	6019456
ZBE08S-10 socket plug (female) 5-pole, bent, with cable, length = 10 m	6023102
ZBE08 Socket plug (female) 5-pole, bent, shielded, with screw terminals	6006786
ZBE30-005 connecting cable CSI-C-11, coupling / plug 5-pole, length = 0.5 m	4193586

ManometerKit

Designation	Part no.
ManometerKit 0-60 bar	3942792

Dimensions

CSM-E with CS1000, HLB 1400 and CSI-C-11

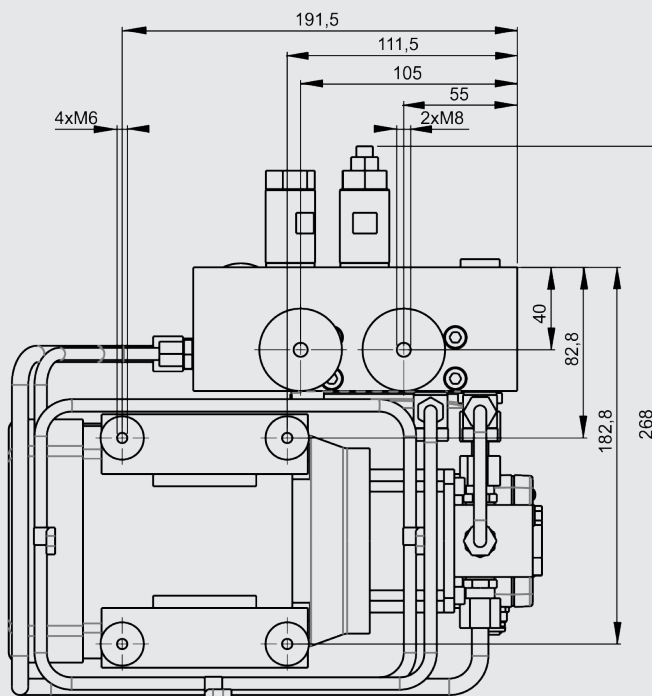
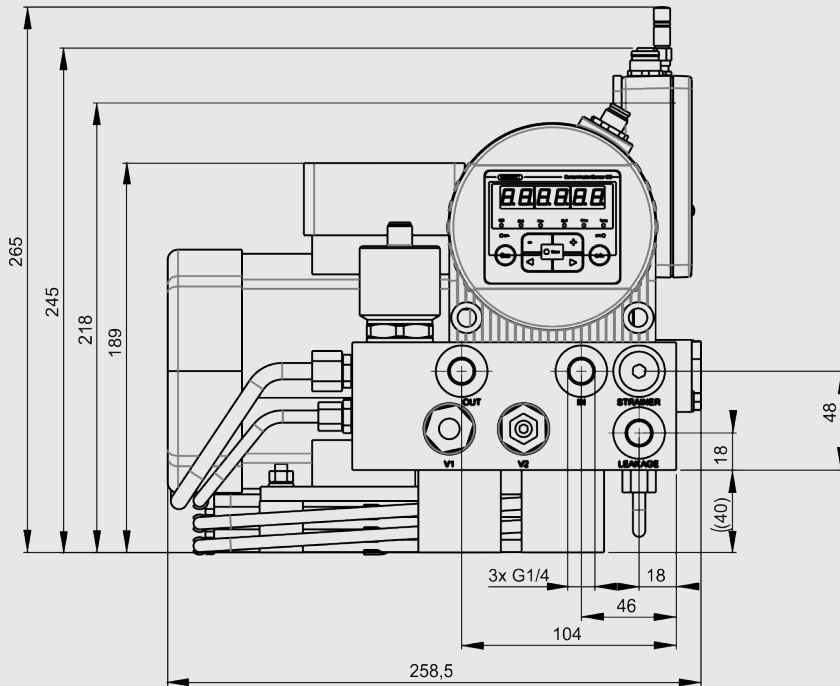

All dimensions in mm

(Scope of delivery without sensors)

Accessories Data Communication and Data Logging

Contamination Sensor Interface CSI-C-11

Designation	Part no.
CSI-C-11-000	4066011
PS5 Power supply 100 – 240 V AC, 50-60 Hz, 1,1 A, IP40; connector M12, 5-pole, female	3399939
ZBE47S-05 connecting cable, socket plug 5-pole with cable, length = 5 m	3527626
ZBE47S-10 connecting cable, socket plug 5-pole with cable, length = 10 m	3527627
ZBE 45-05 network cable (Patch), socket plug 4-pole, coding D / connector RJ45, length = 5 m	3346100
ZBE 45-10 network cable (Patch), socket plug 4-pole, coding D / connector RJ45, length = 10 m	3346101

Sensor Monitoring Unit SMU 1200

Designation	Part no.
SMU1260-TU-00	3467005
SMU1261-TU-00	3791708
SMU1270-TU-00	3704282
SMU1271-TU-00	3805688

Accessories

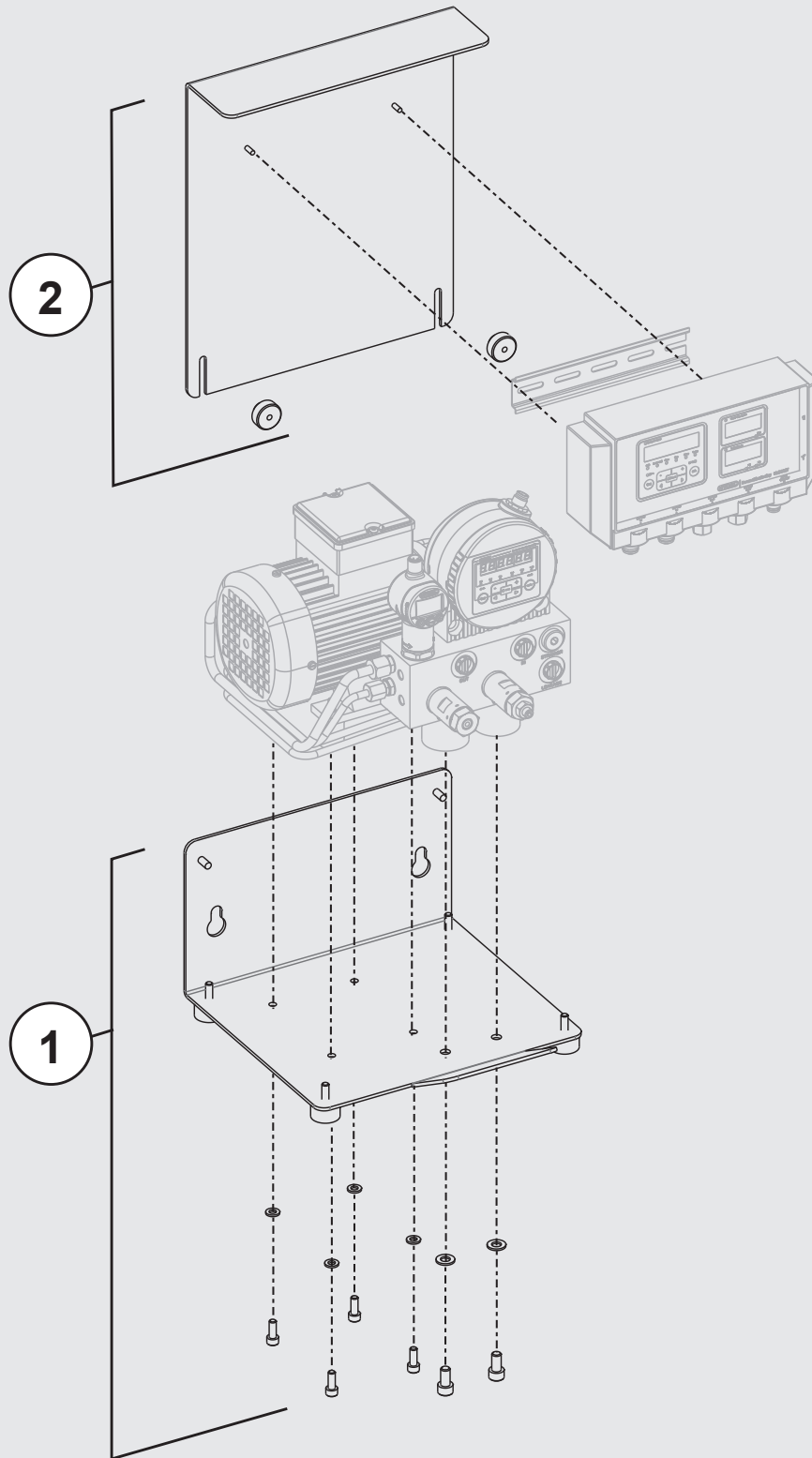

Item	Description	Part no.
1	Assembly kit CSM-E	3942869
2	Assembly kit SMU	3942870

Note

The information in this brochure relates to the operating conditions and applications described.

For applications and operating conditions not described, please contact the relevant technical department.

Subject to technical modifications.

HYDAC FILTER SYSTEMS GMBH

Industriegebiet

D-66280 Sulzbach / Saar

Tel.: +49 (0) 6897/509-01

Fax: +49 (0) 6897/509-9046

Internet: www.hydac.com

e-mail: filtersystems@hydac.com