



Contamination Test Unit CTU 1000 series

Description

The Hydac Contamination Test Unit CTU 1000 series is used to determine the technical cleanliness of lightly contaminated components.

The reasons behind this are the ever increasing demands made on life expectancy of individual components and assemblies which has meant growing demands for technical cleanliness of components and systems. Starting with production, assembly and storage, this extends right through to operation of the complete system.

Analysing the type, size and quantity of contamination enables quality standards to be verified and documented, and the requisite optimisation measures to be implemented.

Applications

- Automotive and supplier industry
- Gearbox and engine builders
- Mobile hydraulics
- Manufacturers of hydraulic and lubrication systems and components

Advantages

- Reduction in costs as a result of less production waste
- Identification and elimination of weak points
- Reduction in production-stage failures
- Optimisation of both internal and external handling processes
- Customer-oriented documentation of the technical cleanliness of components

Technical data

Outer dimensions	See page 79
Weight	CTU10xx: ≈ 270 kg ≈ 290 kg with ultrasonic unit CTU12xx: ≈ 310 kg ≈ 330 kg with ultrasonic unit
Design	Mobile (mounted on casters)
Power consumption	600 W (800 W with ultrasonic unit)
Ambient temperature	15 to 28°C
Analysis chamber (clean box)	
Analysis chamber material	Polished stainless steel
Maximum load capacity	CTU10xx = 47.5 kg * CTU12xx = 47.5 kg *
Control system	PC controlled with user-friendly software, rinse options and rinsing volume programmable
Storage and filtration module	
Membrane holder	For Ø 47 to 50 mm filter membranes
Vacuum nozzle	for extracting the analysis fluid over the membrane
Diffuser	For even distribution of the analysis fluid over the membrane
Operating pressure	-0.8 to 6 bar
Test liquid reservoir	2x 20 l (1x storage reservoir, 1x suction reservoir)
Reservoir switch-over	Automatic
Filtration of test liquid	Fine filtration to ISO 4406 min. ISO 12/9
Filter size, filtration rating	2x MRF-1-E/1, 1 µm
Built-in drip tray	25 litres with drain
Ultrasound	100 W, 40 KHz
Basket for ultrasonic unit	Dimensions: 200 x 110 x 40 mm Mesh width: 4 mm
Emission sound pressure level L _{PA}	< 70 db(A)
To be provided by the operator (not included)	
Compressed air	pre-filtered (min. 5 µm) and dry compressed air, 6.5 to 7.0 bar Air flow rate: 60 l/min, Connection: nipple DN 7.2
Voltage supply	According to order

* For evenly distributed load, no point loading

Preferred models (with shorter delivery times)

Part no.	Model code
4060459	CTU-1040-M-Z-Z
4096185	CTU-1040-M-U-Z
3918423	CTU-1240-M-Z-Z

Model code

CTU 1 0 3 0 - M - Z - Z

Type

CTU = Contamination Test Unit

Series

1 = 1000 series

Size

- 0 = Dimensions of analysis chamber (cleanbox):
300 mm x 765 mm x 365 mm
(height (approx.) x width x depth)
- 2 = Dimensions of analysis chamber (cleanbox):
460 mm x 765 mm x 650 mm
(height (approx.) x width x depth)

Version

- 3 = Version 2011
- Software ConTes
 - 1 µm filtration
 - automatic pressure control
- 4 = Version 2014
- Compression closure, cleanbox
 - Internal extraction, cleanbox
 - filled via 3/2 way ball valve und filling hose
 - Monitor arm (only 124x)
 - Nozzles with plug-in connection (plug-in nipple in analysis chamber)

Test liquid

- 0 = Solvent A III class
Flash point ≥ 60°C, lower explosive limit > 0.6 vol. %)
- 1 = Water with surfactants, permitted pH values 6 to 10,
no deionised water

Supply voltage

- K = 120 V AC / 60Hz / 1 phase USA / Canada
- M = 230 V AC / 50Hz / 1 phase Europe
- N = 240 V AC / 50Hz / 1 phase UK
- O = 240 V AC / 50Hz / 1 phase Australia
- P = 100 V AC / 50Hz / 1 phase Japan

Extraction method

- Z = Spray, medium pressure
- U = Spray, medium pressure plus ultrasound

Supplementary details

- Z = Series
- R = External rinsing connections Ø 6 mm, between manual actions
- F = Fluid connections A/B/C and R fitted with rapid quick-release fastener on outside, Control line to CTM-E modules
- A = Manual change-over for filter membrane holder

Blank values

All data is dependent on the ambient conditions.

Environment	CTU 1xxx		
Clean room	0.1 to 0.2 mg		
Laboratory	0.2 to 0.4 mg		
Separate sampling room	0.2 to 0.6 mg		
Factory building	0.2 to 0.8 mg		
Max. particle size (metallic) [µm]	Time required	Cleaning time [h] after brief shutdown (≤ 24 h)	Cleaning time [h] after extended shutdown (> 24 h)
100*	Great	1.5 ... 4	3 ... 5
150*	Medium	1 ... 2	2 ... 4
250*	Low	0.5 ... 1.5	1 ... 3

* applies to a maximum membrane load of 0.8 mg

Dimensions

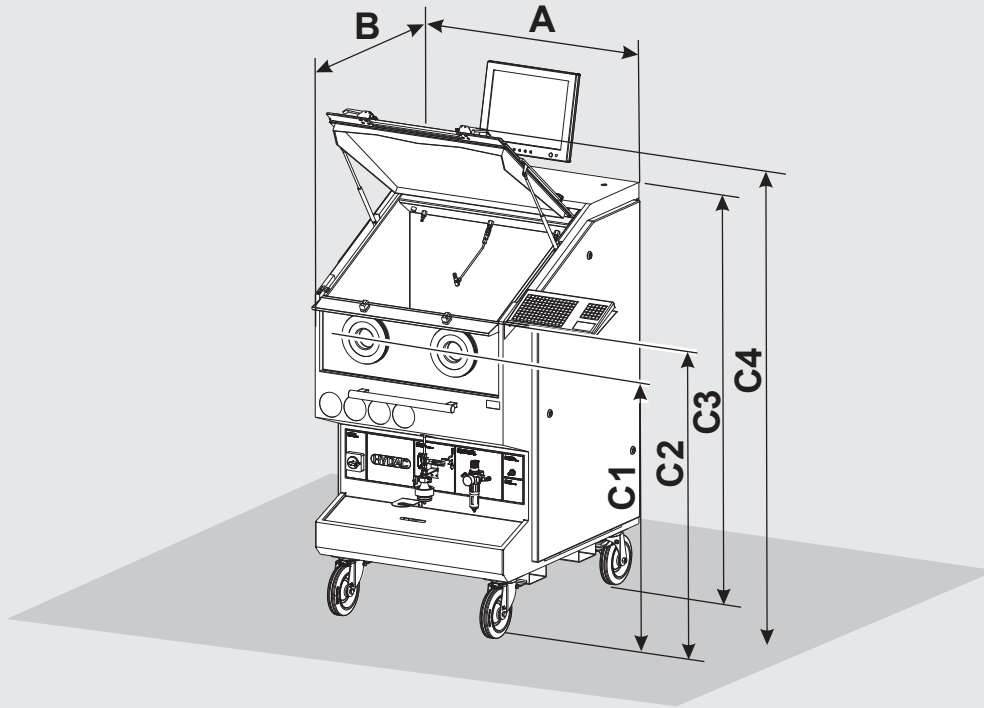

	A	B	C1	C2	C3	C4
CTU10XX	985	850	1170	1290	1500	≈ 1700
CTU12XX	910	1140	1160	1280	1750	≈ 2070

All dimensions in mm

Dimensions of analysis chamber

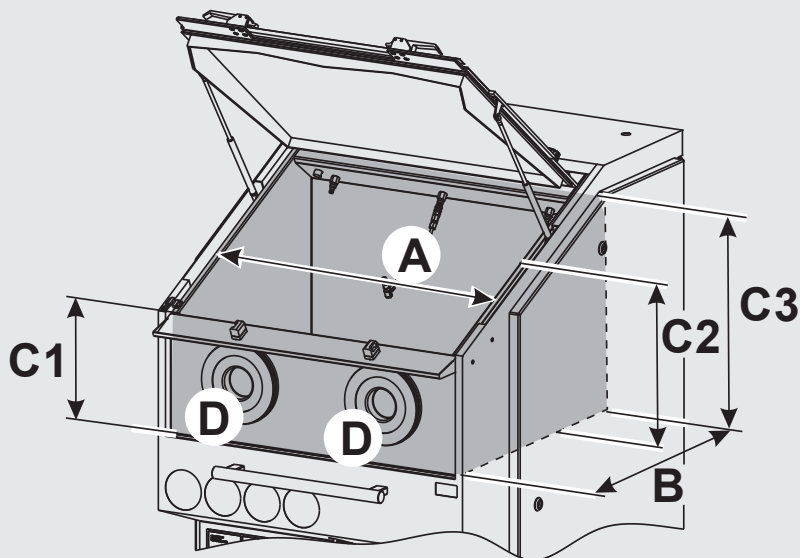

	A	B	C1	C2	C3	D
CTU10XX	765	365	260	335	380	2x Ø 180
CTU12XX	765	650	300	445	560	2x Ø 180

All dimensions in mm

Note

The information in this brochure relates to the operating conditions and applications described.

For applications and operating conditions not described, please contact the relevant technical department.

Subject to technical modifications.

HYDAC FILTER SYSTEMS GMBH
Industriegebiet
D-66280 Sulzbach / Saar, Germany
Tel.: +49 (0) 6897/509-01
Fax: +49 (0) 6897/509-9046
Internet: www.hydac.com
E-mail: filtersystems@hydac.com