

FUNCTION



The accumulator charging valve DLHSD / R is a pilot-operated, spring-loaded spool valve mounted in a manifold or inline housing. Its function is to control the charging of the accumulator within a pre-set switching range. A pilot stage with defined hysteresis, a main piston and a check valve are integrated into the circuit.

The accumulator is charged at port A from pump port P across the check valve. If the pressure in the accumulator exceeds the pre-set value of the pilot stage, the main piston opens and the pump is relieved to tank. If the pressure in the accumulator decreases by the value of the switching pressure differential, the pilot stage closes again and the accumulator is re-charged.

Caution:

- Switching pressures are affected by the pressure at port T!
- Select the largest possible switching pressure differential!
- Ensure that switch-off pressure + accumulator size to pump flow achieves a charging time of >1s!

Accumulator Charging Valve Spool Type Pilot-Operated – 350 bar DLHSD (Manifold Mounting) DLHSR (Inline Mounting)

FEATURES

- Re-charging of the accumulator is dependent on the switch-on pressure, resulting in full accumulator capacity for emergency function in pump intermittent duty mode.
- Switch-off pressures within the pressure ranges 100, 250 and 350 bar freely adjustable
- Very low discharge of the accumulator due to pilot stage with minimal leakage
- Compact design enables space-saving installation in control blocks and power units
- Optimal system adaptation due to valves with different, fixed switching pressure differentials (12, 16, 21%),
- Built-in check valve means no additional installation cost
- Low Δp characteristics
- Various pressure ranges up to 350 bar
- Simple commissioning by setting the switch-off pressure

SPECIFICATIONS

Operating pressure:	min. 0 to max. 350 bar max. 10 bar across tank port T
Nominal flow:	max. 30 l/min
Media operating temperature range:	min. -20 °C to max. +100 °C
Ambient temperature range:	min. -20 °C to max. +100 °C
Operating fluid:	Hydraulic oil to DIN 51524 Part 1 and 2
Viscosity range:	min. 8 mm ² /s to max. 320 mm ² /s
Filtration:	Class 21/19/16 according to ISO 4406 or cleaner
Installation:	No orientation restrictions
Materials:	Valve body: high tensile steel Piston: hardened and ground steel Seals: FKM (standard) Back-up rings: PTFE
Weight:	DLHSD: 2.1 kg DLHSR: 1.5 kg
Line length:	From port A to the accumulator: max. 200 mm; T (tank) or L (drain) lines to the tank must be sized for minimal back-pressure
Switching pressure differential:	12%, 16%, 21% (switching pressures are affected by the pressure across port T)

MODEL CODE

DLHSR - 01 X - 21 / 250

Accumulator charging valve - hydraulic

Controlled by switching pressure differential

DLHSD = manifold housing

DLHSR = inline housing

Type

01 = standard (with check valve)

Series

(determined by manufacturer)

Switching pressure differential

12 = minus 12% of switch-off press. = switch-on pressure

16 = minus 16% of switch-off press. = switch-on pressure

21 = minus 21% of switch-off press. = switch-on pressure

Max. switch-off pressure

100 = 30 to 100 bar

250 = 60 to 250 bar

350 = 100 to 350 bar

Standard models

Model code	Part No.
DLHSD-01X-12/100	561894
DLHSD-01X-12/250	558260
DLHSD-01X-16/100	3345531
DLHSD-01X-16/250	3034027
DLHSD-01X-21/100	3107800
DLHSD-01X-21/250	562729
DLHSD-01X-21/350	3228872
DLHSR-01X-12/100	3192646
DLHSR-01X-12/250	3526092
DLHSR-01X-12/350	3227535
DLHSR-01X-16/100	3069194
DLHSR-01X-16/250	396811
DLHSR-01X-16/350	3195654
DLHSR-01X-21/100	561385
DLHSR-01X-21/250	3126516

PERFORMANCE

Measured at:

$v = 46 \text{ mm}^2/\text{s}$, $T_{\text{oil}} = 40 \text{ }^\circ\text{C}$

DLHSD-01X-12/100

P→B

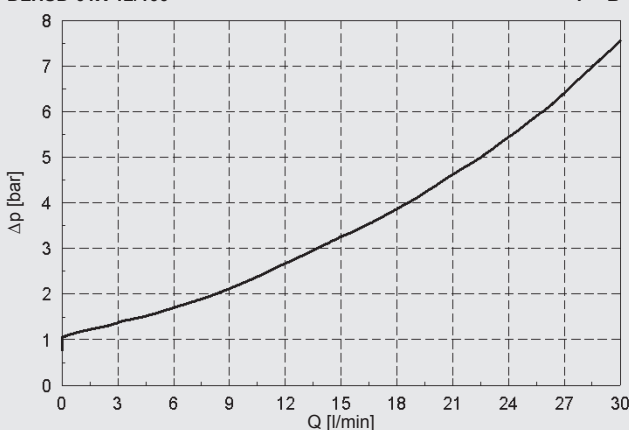

DLHSD-01X-12/100

P→T

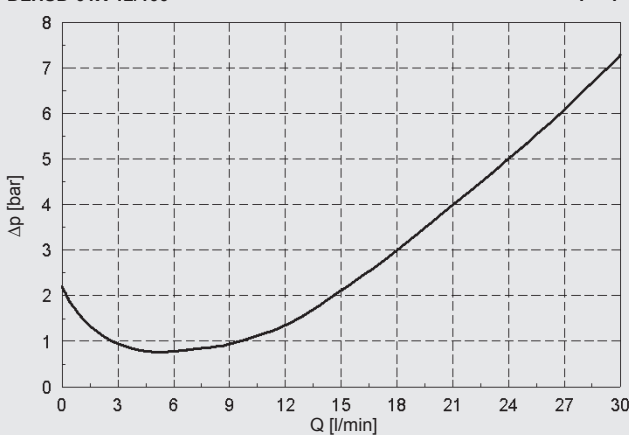

DLHSR-01X-12/350

P→A

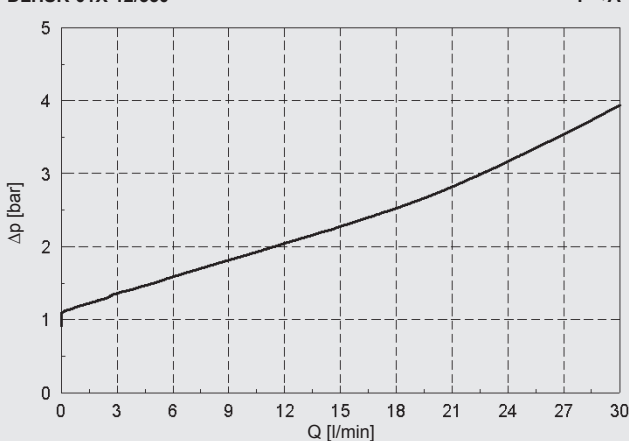

DLHSR-01X-12/350

P→T

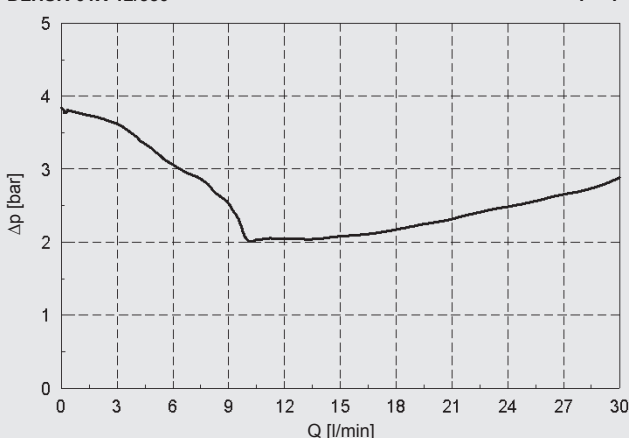

DIMENSIONS

DLHSD

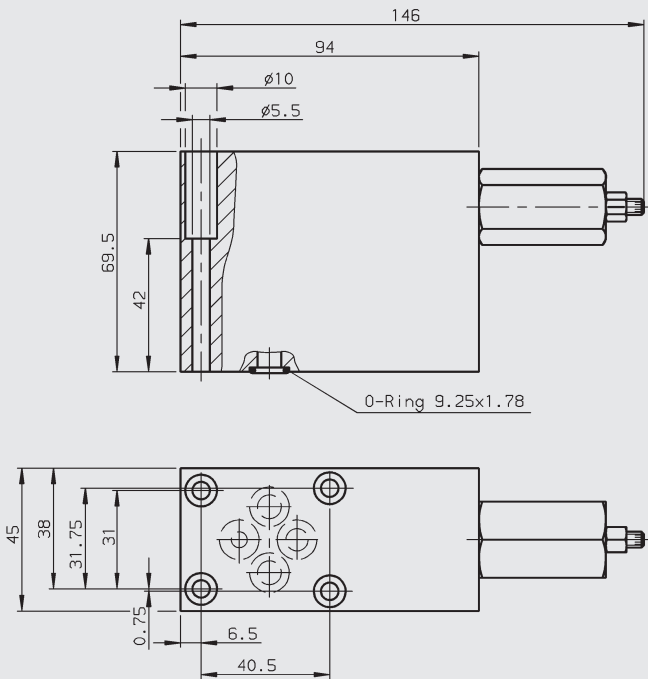

CIRCUIT DIAGRAM EXAMPLE

DLHSD

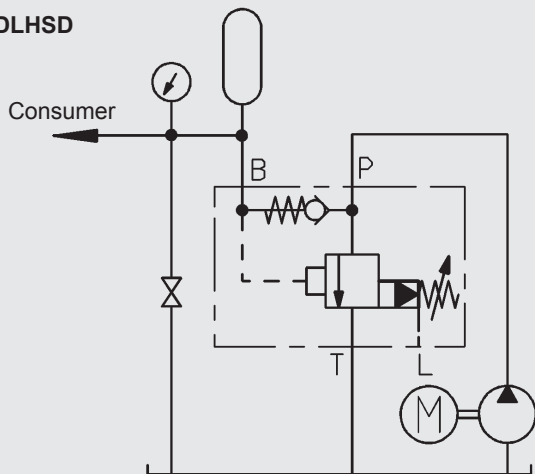

Interface A6 DIN 24340
and CETOP R 35 H-4.2-4-03

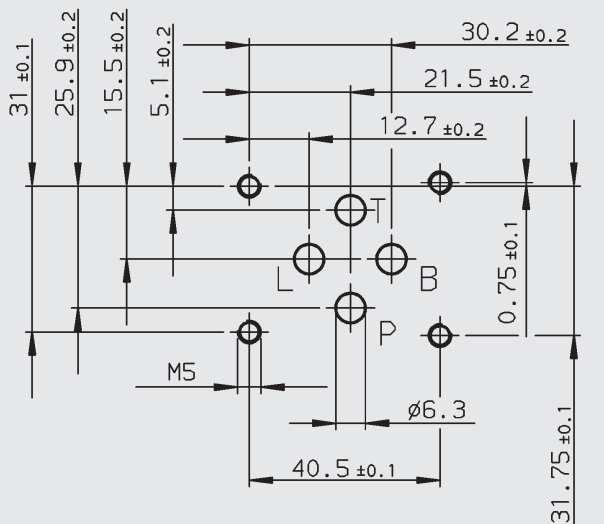

Millimeter (Inch)
Subject to technical modifications

DIMENSIONS

DLHSR

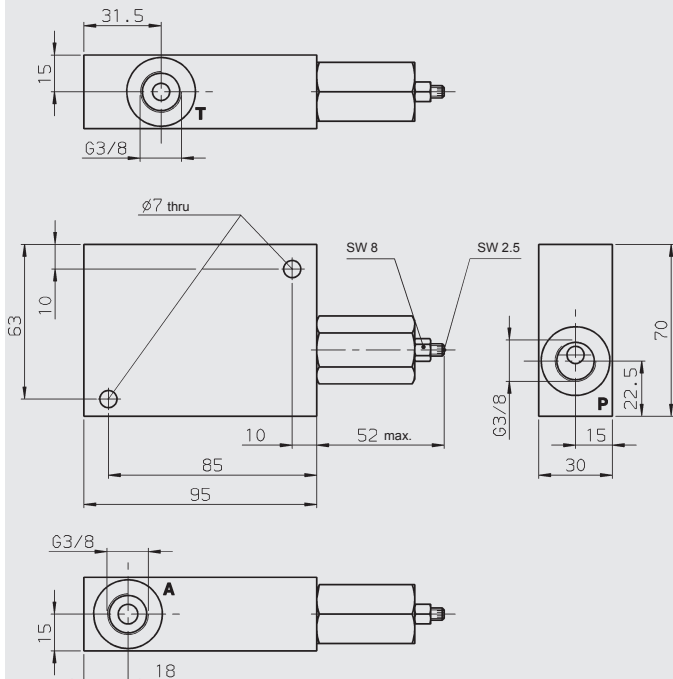

CIRCUIT DIAGRAM EXAMPLE

DLHSR

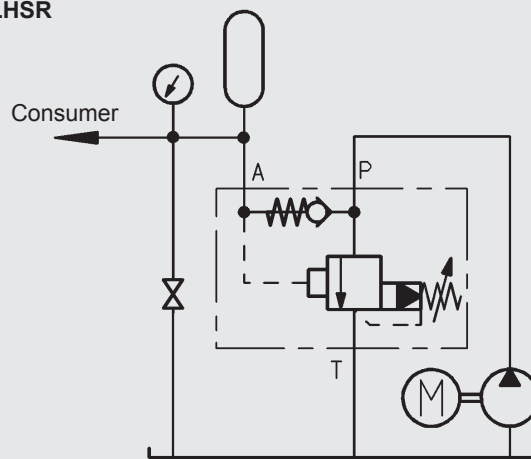

Millimeter (Inch)
Subject to technical modifications

NOTE

The information in this brochure relates to the operating conditions and applications described. For applications or operating conditions not described, please contact the relevant technical department. Subject to technical modifications.

HYDAC Fluidtechnik GmbH
Justus-von-Liebig-Str.
D-66280 Sulzbach/Saar
Tel: 0 68 97 / 509-01
Fax: 0 68 97 / 509-598
Email: flutec@hydac.com

SIDEX

E 5.190.1.0/01.13